

<http://www.Tech-Notes.tv>

December 18, 2008

Tech-Note – 141

First Edition: May 18, 1997

Our purpose, mission statement, this current edition, archived editions and other relative information is posted on our website: WWW.Tech-Notes.TV
This is YOUR forum!

Index

Note: All **Blue** underscored items in this PDF newsletter are working links.
 (Click on the Link below to navigate to that section of Tech-Notes)

[Editor's Comments](#)  [Feature](#)  [Parting Shots](#)
 [Subscriptions](#) 

Editor's Comments

Yes it has been some time since I've gotten an edition of the Tech-Notes out. There are a plethora of topics that should be covered and haven't. Since the publication of this fine journal and the Taste of NAB Road Show is a one man job, there just doesn't seem to be enough time to get it all done in a manor you deserve. I'm not complaining, just stating fact.

Speaking of the Taste of NAB Road Show, I'm in the process of putting together the 2009 tour. I've already got some of the sponsors booked as well as some of the venues. With the economy heading for the dumpster, needless to say purveyors of equipment need maximize their educational or marketing dollars. They can, of course do this by joining, with the lease amount of effort on their part, on the most successful marketing effort in the broadcast industry, or so I've been told, "The Tech-Notes Taste of NAB Road Show." The stats speak for themselves: http://www.tech-notes.tv/Taste_of_NAB.html. 2009 will be my 8th year and, as I said earlier, I'm in the process of putting that tour together right now.

If anyone is interested, they can see all I've done for these past seven years on our website www.tech-notes.tv/Taste_of_NAB.html. You might want to check out the documentary on this year's Taste of NAB Road Show at www.tech-notes.tv – Click on "A Taste of NAB video" (this is a large file and may take up to 4 minutes to download. Running time is about 17 minutes. Year number eight should be a record breaker in all respects.

Those who know me know that I am very passionate about what I do. There is no way anyone has ever duplicated what I do with the Taste of NAB Road Show: some have tried, but fallen very short!

These stats speak for themselves.

Totals for all seven years

Year	# Venues	Total Attendance	Attendance average per venue	Miles	E-mail
2002	31	450	14.5	13,500	?*
2003	36	1055	29.31	14,000	40
2004	48	1105	23.02	18,000	124
2005	65	1447	22.26	20,000	190
2006	51	1430	28.04	16,800	135
2007	52	1303	25.06	18,671	145
2008	<u>75</u>	<u>1914</u>	<u>25.52</u>	<u>20,974</u>	<u>195</u>
Totals	358	8704	24.31	103,293	828

*We didn't keep track that first year.

Note: I am culling through the stacks of information I've collected and will return at my earliest ability to give you another edition of these Tech-Notes.



With the transition to digital of the Full Power television industry less than two months away, it is only fair that I provide you with whatever tools I can to help in this effort. To this end, I've worked with a good friend and associate, Gary Sgrignoli, DTV Transmission Consultant and partner in Meintel, Sgrignoli, & Wallace. Sgrignoli holds a significant number of patents in digital television transmission technology and many of you have attended his many seminars across the country. It is safe to say that there is probably no one better qualified to address DTV, the transition and the problems that may arise during these next few months.

It is both my privilege and pleasure to pass this document on to you, It should be of great assistance to you, answer most all of you question and authored by Gary Sgrignoli. I've not seen anything to equal it. It is with his permission that I share it with you.



A List of
Frequently Asked Questions
(FAQs)
Regarding the
Digital Television Transition

December 17, 2008

Prepared By:



Gary Sgrignoli
Meintel, Sgrignoli, & Wallace, LLC
1139 Juniper Lane
Mount Prospect, IL 60056
(847) 259-3352

DIGITAL TELEVISION TRANSITION: FAQs

GENERAL DTV INFORMATION	3
DTV TRANSITION INFORMATION	9
COUPON ELIGIBLE CONVERTER BOX (CECB) PROGRAM	16
DTV SPECTRUM ALLOCATION	21
PROPAGATION FUNDAMENTALS	25
ANTENNAS	28
PREAMPS, CABLE, AND SPLITTERS	33
DTV RECEIVERS	35
DTV RECEPTION TECHNIQUES	42
MORE INFORMATION	51
GLOSSARY	56

The material in this FAQ handout is a combination of original information and on-line material. The on-line material comes from the following websites:

- www.dtv2009.gov (NTIA website)
- www.fcc.gov (FCC website)
- www.dtvanswers.com (NAB website)
- www.digitaltips.org (CEA website)
- www.antennaweb.org (CEA & NTIA shared website)

Whenever possible, the original DTV-related material from their website was used, and just combined with the original material for best organization. However, there were times that the material was edited for enhanced descriptions and easier flow of reading. The reader is urged to use *all* of the above websites, plus the specific website URLs list in the FAQ list.

This FAQ list is written for the *broadcast engineer and technician* who will be dealing with the DTV transition first hand. The information that follows tries to provide simple questions that a DTV viewer might have, and some straightforward answers for those questions. However, the answers are not necessarily written in the simplest of terms for the laymen, but need further “translation” (simplification) by the station engineers if it is to be used directly with viewers or with television station public relations personnel who will deal with viewers.

DTV TRANSITION: FREQUENTLY ASKED QUESTIONS

GENERAL DTV INFORMATION

Q: What is *analog* television?

Analog television is the long-time traditional method of transmitting signals to viewers' homes. The black and white television system, developed and documented by the National Television Systems Committee (NTSC), was selected by the Federal Communications Commission (FCC) to be the U.S. broadcast standard in May 1941, while the compatible color television system was selected by the FCC to be the U.S. broadcast standard in December 1953. The FCC is the U.S. federal agency that oversees the nation's airwaves.

In analog television broadcast, there is a relatively simple relationship between the picture and sound information that is sent to the visual and aural transmitters for modulation onto an RF carrier, and how the analog television receiver works. In analog television, the *power* of the visual transmitter's RF carrier is varied in a direct relationship to the picture brightness is so that all that the receiver has to do is monitor the power level of the signal it is receiving and adjust the brightness of the image in time with this power change. Sound has a very similar direct relationship, but rather than varying the power, the *frequency* of the aural transmitter's RF carrier varies in direct relationship to the loudness of the sound.

However, analog television transmission is not as efficient as digital transmission, only allowing one TV program to be transmitted on one 6 MHz television channel. It also uses up a great deal of the spectrum as many RF channels (called "taboo channels") in each city have to lie dormant to allow interference protection zones (called "spectrum guard space") for each utilized RF channel. Analog transmission is also not efficient in its use of transmitted power, as it requires significantly more power to serve a region than digital television (DTV).

Since there is a direct relationship in analog transmission between transmitted visual carrier power level and video and between transmitted aural carrier signal frequency and audio, any impairments and interference *directly* impact the picture and sound at the analog receiver. Under these conditions, the picture and sound degrade proportionally as the impairments and interference increase, and, if severe enough, become unwatchable or unintelligible. Each type of impairment has a very distinct impact on the picture or sound that can be directly observed and diagnosed, which is why the analog television set is sometimes referred to as the "window to the RF world." Therefore, analog transmission is very susceptible to propagation impairments, such as white noise (weak signals), multipath propagation ("ghosts"), impulse noise (appliance motor "white speckles"), as well as interference from other television signals.

Q: What is *digital* television?

Digital television, called DTV for short, is an innovative, flexible, and efficient type of broadcasting technology that utilizes computer-like data (i.e., ones and zeros) to represent video and audio in such a way as to provide crystal-clear pictures and compact-disc-quality multi-channel sound in a viewer's homes. It also provides more programming choices (multicasting) than traditional analog broadcast technology, as well as interactive capabilities and data services such as significantly enhanced closed

captioning (for the hearing impaired) and descriptive video (for the visually impaired). This system was developed and documented by the **Advanced Television Systems Committee (ATSC)** in November 1995, and then selected by the FCC to be the U.S. standard in December 1996. DTV is essentially transforming television as it is known.

The picture and sound go through a process of analog-to-digital conversion in the television studio where they are converted into streams of numbers, similar to what DVD, CD, and MP3 players use. In order to squeeze these signals through the 6 MHz television transmission “pipe” (i.e., RF channel), a complex process called compression removes as much of the redundancy in each signal as possible with minimal noticeable effects to reduce the “size” of the video and audio signals. Therefore, due to these sophisticated compression techniques, one DTV *channel* might contain four or five standard-definition television (SDTV) *programs* or it might contain one high-definition television (HDTV) *program plus* two or three SDTV *programs*. Compare this to one analog channel that can only carry one SDTV program. DTV technology can also be used to deliver future interactive video and data services that analog just can’t provide.

Since the video and audio signals are digitally transmitted as a stream of numbers, any impairments and interference will interrupt the data stream causing data errors (i.e., glitches). These errors will confuse the decoding process in the receiver that converts the picture and sound from digital back to analog. Rather than seeing the actual impairment or interference on the DTV screen as one would see on an analog set, the viewer will only see the resulting *effect* of the data errors on the digital set. These effects, which can be caused by the presence of weak signals, impulse noise, multipath, or interference, will show up as “blockiness” (called compression macro blocking) and audio drop outs. If the data errors are severe, a complete video freeze frame or complete audio muting might occur.

Q: Why does *digital* television have the *potential* for being better than analog television?

Built into the digital television transmission signal is extra (i.e., redundant) information that is used for error correction. Error correction is a powerful tool that allows the digital receiver to provide extraordinarily high quality video and audio to the television viewer, even when the received signal is impaired. Signal impairments, which would show up on an *analog* television receiver as “noisiness” from weak signals, “ghosting” from multipath, or “speckles” from impulse noise, and thus degrade the picture and sound even to the point of being unacceptable, can still be viewed without any degradation on a DTV set. It is only when the impairment becomes so severe that it goes beyond the error correction capability (i.e., beyond the threshold of errors) that the DTV signal quickly becomes unusable.

This *sudden* change from an error-free perfect picture and sound to an all-error frozen picture and muted sound is called the digital “cliff effect.” It is this digital cliff effect that allows over-the-air viewing to be potentially better than analog viewing, providing the received digital signal quality is above the cliff, i.e., above the threshold of data errors.

It should be understood that even an *unimpaired* analog video signal on an analog set will not look as good as an error-free digital SDTV picture on a digital set due to the analog *transmission* system’s inherent limitations. This can be observed by comparing a clean over-the-air NTSC signal with a DVD playback signal. The digitally-coded DVD wins hands down over the analog NTSC signal. Of course, HDTV will look even better with five times the detail (twice the horizontal resolution, twice the vertical resolution, and 25% wider aspect ratio) as a clean analog signal.

Years ago, when cable television delivery was in its infancy (before satellite delivery directly to the home), it was generally understood that, besides extra programming, a viewer could expect the same or

better video and audio than a terrestrial broadcast signal. However, in this DTV era, the broadcast signal can now provide the same or better video and audio than cable (likewise for satellite).

Q: What are some of the advantages of using digital technology for over-the-air television?

The use of digital technology to transmit television signals in a computer-like data method is much more efficient in terms of spectrum bandwidth and transmitted power than that employed in the 60-plus year old analog system. This frees up more spectrum for public safety (first responders, such as police, fire, paramedics, etc.) as well as new commercial digital communication services, such as broadband Internet connectivity. Also, the television service is enhanced since better video (both standard and high definition, with wide aspect ratios) and audio (multi-channel, compact-disc-quality Dolby AC-3) signals can be transmitted, and more programming can be made available in the form of sub-channels (called multicasting). Additionally, data that is either related to the programming or totally independent of it can also be sent in the same digital stream (called data casting).

The spectrum efficiency comes from a combination of a high data rate (~20 Mbps) that allows more information to be transmitted, a noise-like RF signal characteristic that minimizes interference into other television signals for better channel packing, and robust data reception characteristic due to error correction capability.

Q: What is multicasting?

Using the same amount of spectrum (6 MHz) required for one analog television program, digital multicasting allows broadcasters to simultaneously transmit several SDTV programs in the same spectrum due to the efficiency of digital technology. As the technology has continued to advance, even one HDTV program along with two or three SDTV programs can be transmitted over one 6 MHz DTV channel. This allows viewers more program choices.

Q: What is aspect ratio?

Aspect ratio is the numerical ratio of a video picture's width to its height. The analog NTSC television system that has been around since 1941 uses a 4:3 aspect ratio, which means that the width of the picture is 4 units while that of its height is 3 units. This aspect ratio is rather like a box (but not quite) and is unlike the pictures seen in movie theaters. For example, a 10" diagonal TV set would have a picture width of 8" and a height of 6".

The new ATSC DTV system contains video formats that use a 4:3 aspect ratio, but also contains other video formats that use a 16:9 aspect ratio. A 16:9 aspect ratio provides a more rectangular picture and resembles those seen in movie theaters.

Q: What is datacasting?

Datacasting is a technique that allows a broadcaster to transmit any kind of data (program related or not) interspersed with the video and audio data. Sometimes a fixed amount of data packets is set aside for this ancillary data. At other times, the amount of data that is transmitted varies based on *opportunities* in the video data stream that present themselves when the video does not need a large amount of data (e.g., a fade to black). Transmitting a variable data rate like this is called opportunistic datacasting.

Q: How was DTV developed in the U.S.?

DTV was developed from 1987 through 1995 under the auspices of the FCC's Advisory Committee on Advanced Television Services (ACATS), during which time a competitive race was set up among various proponents to develop a digital High Definition Television (HDTV) system that could be transmitted through the existing over-the-air 6 MHz channels (i.e., "information pipes") to viewers' homes. Starting with 23 proposals, the ACATS group reduced the number of proposals to six systems (2 analog and 4 all-digital) that were built as prototypes and tested in the laboratory. The analog HDTV systems, which were considered in case the digital HDTV systems did not perform acceptably, did not perform well themselves when compared to the digital systems, and they were therefore rejected. The four all-digital systems had both good points and bad points. Ultimately, the proponents of these four all-digital systems merged together in the Grand Alliance and created a "best of the best" HDTV system that was documented by the Advanced Television System Committee (ATSC). ATSC added Standard Definition Television (SDTV) video formats and Enhanced Definition Television (EDTV) video formats to the Grand Alliance's HDTV formats.

On **November 28, 1995**, the ACATS group advised the FCC to select the ATSC system as the next television system for the United States. The FCC then accepted this recommendation and made the ATSC system the U.S. standard on **December 24, 1996**.

The first commercial stations voluntarily began broadcasting DTV in the fall of 1998. However, the FCC-mandated beginning of DTV broadcasting was in May 1999, with the top four networks in the top ten markets required to be on the air with DTV. This was followed in November 1999 with the top four networks in the top thirty markets. By 2003, a vast majority of all the commercial and public stations in all the markets were broadcasting DTV. The full-power stations are currently scheduled to cease their analog broadcasts on **February 17, 2009**, bringing to a close a 10-year transition (excluding the system development time).

Q: What are the various video formats and aspect ratios that might be transmitted to a viewer's DTV set?

The ATSC standard is very flexible, allowing a number of video formats and aspect ratios to be transmitted by digital television stations. Aspect ratio is defined as the relative size of the horizontal picture width to the vertical picture height. Some of these video formats and aspect ratios are displayed on DTV screens when the "Information" button on the remote control is depressed.

There are two type of scanning formats used in the ATSC standard: interlaced ("i") and progressive ("p"). Interlaced scanning means that the picture is "painted" on the screen, with all the odd horizontal lines scanned first in 1/60th of a second followed by all the even horizontal lines in the next 1/60th of a second to create a complete frame of video in 1/30th of a second. This is the traditional method used from the 1940s with the legacy analog television signal. Progressive scanning means that the picture is sequentially "painted" in order (1, 2, 3, 4, 5, ...) to create a complete frame of video in 1/60th of a second.

Some of the DTV formats are Standard Definition Television (SDTV) formats such as 480i that use 480 active lines scanned *interlaced* and provide the traditional 4:3 aspect ratio (the more box-like, square picture). This format is the same format used in analog television from the beginning of its history in 1941, although when transmitted digitally will look sharper and clearer than the analog signals.

Some of the DTV formats are Enhanced Definition Television (EDTV) such as 480p that have the same number of 480 active lines as the SDTV format, but they are scanned *progressively* and use the 16:9

wide aspect ratio (the more rectangular picture used in movie theaters) or the traditional 4:3 aspect ratio (box-like picture). Some DVD players provide a progressively scanned, wide aspect ratio picture that allows enhanced pictures to be viewed on modern digital widescreen monitors.

Some of the DTV formats are **High Definition Television (HDTV)** such as 720p and 1080i. These formats use 720 active lines scanned *progressively* or 1080 active lines scanned *interlaced*, and only use a 16:9 widescreen aspect ratio. While some people feel strongly about one of these HDTV formats or the other, in reality, they both provide very good pictures, with the *progressive* format providing *slightly* better pictures for fast motion video (e.g., fast-action sports) and the 1080 *interlaced* format providing *slightly* better pictures for slower motion higher detail video (e.g., nature scenes). It is highly unlikely that the typical viewer would notice the difference between the two.

Q: What type of audio formats might be transmitted to a DTV viewer's set?

The ATSC system uses the Dolby AC-3 audio compression system that allows up to 5.1 channels of sound (left front, center front, right front, rear left, and rear right) plus one low-frequency sub-channel (omni-directional). This would provide the viewer with 5 full-bandwidth channels (i.e., CD quality) and 1 low-bandwidth base channel (i.e., sub-woofer). Some broadcasters may choose to only transmit left and right stereo channels, but with CD-quality sound. Regardless of what is transmitted by the broadcaster, the sound will be improved over that experienced with analog.

Q: Is digital television the same thing as high definition?

No, high definition television, also known as HDTV, is only one *type* of digital television format. High definition has two video formats (1080i and 720p) and contains approximately five times the detail as today's standard definition format (twice the horizontal resolution, twice the vertical resolution, and 25% wider aspect ratio). There is also standard definition (e.g., 480i) and enhanced definition (480p) video formats. However, all transmitted digital video formats, if received error-free by the DTV set, will look better than today's video signals transmitted in analog form.

An HDTV set is *not* necessary to receive digital television signals. A Standard Definition television (SDTV) digital set as well as a digital-to-analog converter box can likewise receive digital television signals. However, they cannot display high definition pictures, but rather a lower resolution (i.e., lower quality) version of them. Nevertheless, these lower resolution versions, which will be DVD quality, will still look better than the best analog signals received off the air. Also note that SDTV sets are priced comparably with similar sized analog television sets.

Q: What is the television channel numbering scheme used in the ATSC standard?

The original NTSC analog television system was, in essence, created with virtual channel numbers that sequentially covered CH 2 through CH 83 inclusive (which later was reduced to CH 2 through CH 69). However, the actual channel frequencies are not continuous, being broken up into three different bands (low-VHF, high-VHF, and UHF).

The ATSC chose to allow the new DTV channels to also be referenced by *virtual* channel numbers. However, these DTV channel numbers are linked to their original companion analog channels rather than their *actual* digital channel. This allows stations who have particularly branded themselves in conjunction with their analog channel number (e.g., Sports Center 5, Action 7 News, etc.) to continue doing so in the digital-only world after February 17, 2009.

During the full-power station transition in the U.S. from analog to digital (May 1999 to Feb 2009), each eligible full power station was loaned a separate 2nd channel on which to transmit their digital signal while their analog signal was transmitted on their original RF channel. If the original analog signal is on CH 7 (called 7-0), then the new DTV signal's primary digital program is called 7-1, and if there are other digital programs included on this new second channel (such as exists in multicasting), they are called 7-2, 7-3, 7-4, etc. These "virtual" DTV channels are called such because they are not being transmitted on CH 7 where the analog channel currently resides (the analog and digital channels *cannot* share the same actual RF channel), but rather they are being transmitted on some different RF channel such as CH 51. The ATSC system uses a technique called PSIP (Program and System Information Protocol) channel mapping that keeps everything straight in the DTV receiver or converter without the viewer having to worry about remembering the actual RF channels. PSIP data is sent along with the video and audio, and informs the DTV receiver about the virtual and actual channel relationship as well as other important information about the programming that is available from that station.

After the full-power analog signal (i.e., CH 7-0) is turned off on February 17, 2009, the remaining virtual channels (7-1, 7-2, 7-3, etc.) will remain for the viewer to select. However, the actual DTV RF signal may remain on its transition RF channel (e.g., CH 51), or it may move to the station's original analog channel (e.g., CH 7) that has been vacated, or it may move to an entirely new RF channel (e.g., any RF channel in the post-transition core spectrum of CH 2 through CH 51, inclusive).

Q: What are the advantages and disadvantages of using a *virtual* channel reference system for DTV?

The advantage of a virtual channel reference system is that the viewer does not have to know or keep track of the actual DTV channels (especially when some may change channels on or before 2/17/09) and the broadcaster gets to keep his branding has been developed over many years. All that needs to be known is the virtual channel number, even if the actual DTV RF channel changes on February 17, 2009. As long as a channel scan has been performed by the receiver, the DTV converter box or DTV receiver will know the relationship between the virtual channels and their actual DTV channels. This is accomplished by using a technique called PSIP channel mapping which keeps track of the various virtual channels and their related actual RF channels. Likewise, any new DTV stations that come on the air or that have changed channels will be logged into the DTV receiver's channel memory if a rescan is performed periodically, thus simplifying channel selection for the viewer.

The disadvantage is that the viewer may not know the actual DTV RF channel, which is important in receive antenna selection (e.g., VHF-only antenna, UHF-only antenna, or all-band antenna). However, the viewer can easily find out what the actual DTV RF channels are by going to: www.antennaweb.org.

Q: What is the importance of doing a channel scan with a converter box or DTV receiver?

Channel scans are crucial for the DTV converter or DTV receiver in order to "learn" the actual DTV RF channel and pair it with its analog channel. This pairing with the analog channel is how the *virtual* channel is determined. Other data about each DTV channel is also gathered during the scan, such as the station call letters, the number of sub-channels, etc. Rescans should be performed periodically in case there are any changes in the local channel mapping, as may occur just before or just after the analog shutdown date of February 17, 2009.

DTV TRANSITION INFORMATION

Q: What is the DTV transition?

The transition from analog television to digital television (DTV) is the most significant advancement in the television industry since color TV was introduced to the market in 1954. The process to *develop* DTV started in 1987, and was completed when the DTV standard was selected by the Federal Communications Commission (FCC) in December 1996. The FCC is the federal agency that oversees the nation's airwaves (i.e., spectrum). Since a major fundamental nationwide change like this cannot be accomplished overnight, the preparation continued in 1997 when every eligible full-power station was *loaned* (i.e., authorized) a second RF channel to exclusively use for digital television transmission during an extended transition time. During this transition time, each station was required to simultaneously transmit *both* an analog and digital signal. That is, stations were expected to transmit their traditional analog television signal on their old TV channel, but simultaneously transmit a digital signal on their newly acquired DTV channel. As consumers bought new DTV sets during the transition, they would have the *option* of viewing the new and improved DTV signals.

The actual full-power transition from analog television to *exclusive* use of digital television formally began in May 1999 and will be completed on February 17, 2009 at 11:59 pm when all *full-power* analog signals will be required by Congressional law (Digital Television Transition and Public Safety Act of 2005) to be turned off. Low-power television (LPTV) stations will *not* be required to complete their transition to *exclusive* DTV transmission until some time after February 17, 2009, a date that has yet to be determined by the FCC (*perhaps* in 2011 or 2012).

The FCC has issued a number of very helpful consumer advisories on the DTV transition at: www.dtv.gov/publications.html.

Q: Will our neighbors to the north and south also be transitioning to digital television?

Canada and Mexico both have adopted the ATSC digital television standard, and will ultimately transition to digital at some time in the future. This is important since many U.S. residents watch programming from stations across the border as well as U.S. stations. However, these countries will not complete their transitions at the same time as the U.S. Canada is not expected to complete its transition until August 2011, and Mexico is not expected to complete its transition until 2021. Since these viewers near the border will only see full-power U.S. stations in digital after February 17, 2009 yet will continue to receive either Canadian or Mexican stations in analog for awhile, it definitely would be wise for these viewers to purchase a converter box that has an *analog pass-through* option included. A list of converter boxes that have the analog pass-through capability can be found at: www.ntiadtvtv.gov/cecb_list.cfm.

Q: How many households are estimated to receive over-the-air signals in their homes?

Thirty-four million *homes* are estimated to receive free, over-the air television signals. This includes about 19.6 million households who *exclusively* watch terrestrial broadcast television plus about 13.4 million households who subscribe to pay services, but have additional television sets that are not connected to these services. A total of about 70 million TV sets are at risk of losing their free television signals after February 17, 2009 if no action is taken in these households.

Q: Is there a *switch* in free, over-the-air television broadcasting from analog to digital that will occur on February 17, 2009?

NO, there is **not** a “switch” to digital on February 17, 2009. The “switch” to digital has already occurred, starting in May of 1999 when *full-power* stations in the top 10 markets began transmitting a digital signal (call letters ending in –DT) in addition to their analog signal. This process of *simulcasting* both analog and digital television signals has continued ever since. Today, viewers can receive analog signals from about 1760 television stations and digital signals from about 1631 television stations (about 93% of the total stations).

On February 17, 2009, all the *full-power* analog stations nationwide are required by law, as stated in the Deficit Reduction Act of 2005, to turn off these analog television signals and broadcast *exclusively* in digital. Note that there are some *possible* exceptions near the Mexican border subject to future Congressional action, and low-power television (LPTV) stations and translators are already exempt from this particular analog turn-off date.

Therefore, full-power DTV service is available **NOW** for over-the-air viewers to experience with either a DTV set or a converter box. There is no need to wait until February 17, 2009 (last day of full-power analog broadcasts) to start enjoying the benefits of DTV. Local program listings of the DTV channels provide programming information.

Q: Will the February 17, 2009 date for the end of full-power analog television broadcasting be pushed back?

While not impossible, it is unlikely since it would actually take an “act of Congress” to do so since Federal law mandates this date as the last day of *full-power* analog television broadcasts. Also, most of the spectrum has already been auctioned, with the winners of these auctions waiting to claim their spectrum for commercial use. Additionally, 24 MHz in the upper channels (CH 63, CH 64, CH 68, and CH 69) have been allocated by the government for long-awaited and very important public safety use (both narrowband voice channels and broadband data channels). Many public and private groups are working very hard to meet the February 17, 2009 analog turn-off date.

Q: What are television *translators* and *low-power* television stations, and must they turn off on February 17, 2009?

A TV translator station rebroadcasts the programs of a full-power TV broadcast station. Translator stations typically serve communities that cannot receive the signals of free, over-the-air TV stations because they are too far away from a full-power TV station or because of geography (e.g. mountains). Many translator stations typically operate in mountainous or more remote areas of the country. If one is watching a full-power station program (e.g., CH 12), but the analog television set is tuned to CH 25, a translator is being utilized. There are over 4700 licensed translators, and they are identified with their channel number in the middle of the call letters (e.g., K25ZZ).

The FCC created the Low-Power Television (LPTV) service in 1982 as a *secondary* service to full-service stations (i.e., they can not interfere with full-power stations and they can be displaced by full-power stations, if necessary). An LPTV station is limited to broadcasting at an effective radiated power of 3 kW for VHF and 150 kW for UHF. LPTV stations typically provide locally-oriented and locally-created programs or specialized television services in the communities that they serve. These communities may be in rural areas or they may be individual communities within larger urban areas. LPTV stations are usually operated by diverse groups and organization (private and public), and can

include satellite-delivered programming services, syndicated programs, movies, and a wide range of locally-produced programs. More than 2,100 licensed LPTV stations are in operation, and they identify themselves on the air regularly with the name of their community of license and their call letters which end in –LP (for Low-Power).

Class A stations are a particular type of LPTV station that has certain interference protection rights (“primary” status) not available to LPTV stations (“secondary” status). While similar in technical design to LPTV stations, Class A stations must broadcast at least three hours of locally-produced programming each week and comply with many of the non-technical FCC regulations applicable to full-power stations (e.g., identifying themselves regularly, either visually or aurally). Approximately 600 Class A stations exist, and they identify themselves with call letters that end in –CA (for Class A).

Neither translators nor LPTV stations are required to cease analog transmission on February 17, 2009, but will soon have some later date set by the FCC for their required analog turnoff. However, they are currently *allowed* to “flash cut” to digital, i.e., cease analog transmission and *immediately* begin digital transmission on the original analog channel, at any time (either before, on, or after February 17, 2009). As a matter of fact, there already is a small percentage of LPTV stations and an even larger percentage of translators already transmitting digital signals. Undoubtedly, when the rest decide to switch to digital, they will announce their conversion date in advance. If in doubt, one can check with the local community officials to ask about translator or LPTV conversion plans.

If viewers are watching both full-power digital stations and analog translator or low-power stations *after* February 17, 2009, a converter box with analog *pass-through* would be most appropriate for LPTV and translator viewing. These converter boxes allow antenna signals to pass around the built-in digital tuner to the RF output and to the legacy analog television set when the converter box is turned OFF. This adds convenience for the viewer so that there is no need to use an external switch or signal splitter with the converter box. However, not all NTIA-certified converter boxes have the analog pass-through feature. Therefore, a consumer must be careful to take note of the features of a converter box that is being purchased. A list of the certified converter boxes with analog pass-through (denoted by an asterisk) can be found at: www.ntiadtv.gov/cecb_list.cfm. Of course, a new DTV set with built-in DTV tuner can provide both analog and digital reception.

A list of translators and LPTV stations can be found at: www.ntia.doc.gov/lptv/LPTV_il.html. In order for a viewer to determine the LPTV stations in their particular area (based on zip codes), go to the following website: www.lptvanswers.com/.

Q: Why has the government decided to transition from analog to an all-digital over-the-air television system?

Under legislation passed by Congress (Deficit Reduction Act of 2005), free local over-the-air broadcast stations are required to cease broadcasting in analog at the end of the day on February 17, 2009. The government is taking advantage of the efficiency of this new digital television technology to provide for the potential of a better over-the-air viewing and listening experience for the public (including improved services such as enhanced closed captioning) as well as more programming (multicasting) and data services (datacasting).

Additionally, this DTV system efficiency will also provide valuable and scarce broadcast spectrum since DTV requires less spectrum than analog TV since it can be better packed into the television spectrum. This extra spectrum will not only be used for improved emergency communication between various public safety groups like police, fire, rescue squads, and other emergency rescue personnel (i.e., first

responders), but it will also be used for spectrum auction (deficit reduction) to companies that will provide important and new innovative advanced wireless services (such as wireless broadband connectivity).

Q: Who is affected by this transition to digital television?

Any viewer who watches free, over-the-air television by receiving its signal from either an outdoor or indoor antenna will be affected. Those who watch their television via subscription (pay) services, like those provided by cable, satellite, and telephone companies, will not be affected. However, many homes using these pay services have *additional* television sets (e.g., in kitchens, bedrooms, etc.) that receive their signals only from antennas. These TV sets that are not connected to the pay service will also be affected by the transition to exclusive digital broadcasting on February 17, 2009.

One estimate indicates that approximately 20 million homes receive free, over-the-air television exclusively, and about another 14 million households have secondary over-the-air television sets in bedrooms and kitchens. Therefore, almost 34 million households risk losing free, over-the-air television reception on at least one TV set, with a total of an estimated 70 million analog TV sets going blank if nothing is done to avoid this.

Q: What options are available to these households that are at risk of losing television service on February 17, 2009?

There are *three* basic options to consider:

- 1) Purchase a DTV converter box for the existing analog TV set (*most* units cost between \$50 and \$70).
- 2) Purchase a new DTV set that has a built-in DTV tuner that is compatible with the new DTV signals.
- 3) Subscribe to some pay TV service, such as those offered by cable, satellite, or telephone companies. Remember that not all cities will have all the *local* television programs as part of their pay service.

More information can be found at: www.DTVtransition.org.

Q: When can viewers begin to experience free, over-the-air DTV?

In the past it seems that free, over-the-air DTV has been one of the country's best kept secrets despite its deployment back in 1999. However, it is widely available across the U.S. today, and has been available in most markets since 2003. This includes both high definition and multicast standard definition. Therefore, viewers can begin receiving and experience true DTV today with an NTIA-certified converter box and even HDTV with a proper HDTV receiver with built-in digital tuner.

Q: Will there be some quick (i.e., temporary) analog shutdown tests to warn the public about the impending analog shut-off?

Yes, these brief tests allow TV viewers the opportunity to determine whether they need to take action in the near future to prevent their TVs from losing programming after February 17, 2009.

For example, a local broadcast station might *simulate* "pulling the plug" on its *analog* transmission for a short interval (30 seconds, 1 minute, few minutes, etc.) while the station's digital program feed continues uninterrupted. Pulling the plug can mean turning off the analog transmitter, but more likely

the station will just transmit on its analog transmitter a slide with text and some pre-recorded audio indicating that the viewer needs to take action if there is a desire to continue receiving free, over-the-air programming after February 17, 2009.

Therefore, all viewers using legacy analog television sets without converters will see either static or see the slide telling them that they will lose their television programming next February 17, 2009 if no action is taken before the analog turn-off occurs.

Meanwhile, those viewers watching this test on a DTV receiver (with built-in digital tuner) or their legacy analog television receiver that is connected to a converter box will continue to see regular programming. Likewise, cable and satellite operators should be receiving the local station's signal for retransmission by means *other* than the station's analog signal, and therefore would also continue showing the station's programming during this short test interval.

These types of brief tests are sometimes called "soft tests" since there is not a *final* shutdown of the analog transmitters, but rather a short, temporary one. They can be very effective as a first step in calling people to action.

Q: Is it possible that some TV stations may turn off their analog signal forever sooner than February 17, 2009?

Yes, some stations have been given permission from the FCC to turn off their analog signals *before* February 17, 2009, assuming that they meet certain criterion that the FCC feels is in the best interest of the public. As the federally-mandated analog turn-off date of February 17, 2009 approaches, more analog stations will be allowed to shut down early in order to facilitate their final readiness for the all-digital area.

Some stations are transmitting now on their final post-transition digital channel using their final transmitter antenna. However, others will ultimately need to move their digital transmit antenna to a more optimum location on their tower, such as at the very top of the tower rather than at a lower height on the side of the tower. Some stations must actually switch RF channels for their DTV signals, such as returning to their current analog RF channel (that will be ultimately evacuated) or even moving to a new third RF channel. These situations are also logistically difficult (including dealing with winter weather for many cities), and the FCC is helping these stations by allowing them to turn off analog earlier than the federally-mandated date. However, the FCC *requires* that these early analog station shutdowns meet certain public obligations in order to guarantee that the public has been properly and sufficiently forewarned prior to the shutdown.

Q: Why can't the analog shutdown be performed in phases over time?

The problem is that parts of the spectrum (CH 52 – CH 69) are required by law to be vacated immediately following February 17, 2009 for public safety and for auction winners to use for advanced wireless broadband Internet services.

Other stations cannot move to their new final post-transition channel until is vacated by the incumbent analog station. Also, interference planning is based on certain principles that would not hold true if all the stations did not move simultaneously.

Q: What do cable customers have to do when analog over-the-air broadcasting ceases?

Nothing, as long as all of the TV sets are connected to cable system provider! The February 17, 2009 analog cessation deadline applies only to *full-power broadcast* stations. The government does not require cable companies to transition their systems to digital, and they can continue to deliver analog channels to their customers if they desire.

As a matter of fact, the FCC rules *require* that cable operators offer local broadcast stations for their customers in analog form if they are still delivering any analog service on their system after February 17, 2009. This mandated requirement is valid for at least three years after the February 2009 full-service analog turn off (i.e., until 2012). However, this mandated requirement will be reviewed by the FCC in 2011 to see if it needs to be extended beyond 2012. This means that cable customers who receive analog cable service (i.e., *without* a cable set-top box) will be able to continue doing so. After this FCC cable mandate ends, then these cable customers will have to decide how they want to continue receiving their television programming.

While the FCC is not requiring cable systems to convert to digital, some cable systems may convert part or all of their system to digital *voluntarily*. If they do so, cable viewers may have to rent or lease cable converter boxes (i.e., for a fee) to use with their legacy analog receivers or buy new digital cable-ready (DCR) television sets equipped with a CableCard slot. However, any cable converter box that is used in this situation is not the same as the converter boxes used in the NTIA's over-the-air coupon program.

Of course, any analog TV sets in a cable TV household that are not connected to this pay service, but rather use an over-the-air antenna, must take action to continue receiving free television.

Q: Does the DTV transition affect TV sets connected to satellite TV pay service?

The DTV transition is for over-the-air broadcast stations only, and not for pay services like satellite (or cable). Satellite systems already use all-digital signals, and they require the viewer to use a converter box compatible with their system. However, not all cities have satellite service that contains local broadcaster signals, which can be determined by calling the satellite provider directly and asking. If not, a converter box and broadcast antenna may solve this problem.

Q: Without a converter box, will the legacy analog television sets be totally useless?

No, they will not. Besides working with converter boxes to receive over-the-air digital broadcast signals, they can still be used with older analog VCR and DVD units as a playback display device, as well as with older analog gaming consoles and similar products. Of course, if these legacy analog sets are connected to cable or satellite television subscription services, they will continue to work after February 17, 2009.

Therefore, older analog television sets will not have to be thrown away, but rather can be recycled or repurposed.

Q: Will handheld or battery-powered TV sets work after February 17, 2009 if used with a converter box?

In *principle*, yes they can. However, it is *unlikely* that they will work with a converter box since many of these handheld battery-operated TV sets do not have an RF input F-connector (i.e., the antenna in these devices internally connects directly to the handheld or portable TV with no way to remove it) or

baseband video and audio input RCA jacks. If these things are true, these units can not be connected to a converter box.

Also, at this time, there are few battery-operated converter boxes, although some external power devices can be used to operate the converter box (rechargeable battery packs with an AC inverter, uninterruptible power supplies, car battery adapters, and small power generators). At least one converter box manufacturer sells a separate battery pack for its converter.

An alternative is to purchase a portable, battery-operated DTV set. This device would be marked with words like “Integrated Digital Tuner”, “Digital Tuner Built-in”, “Digital Receiver”, “DTV”, “ATSC”, or “HDTV”. There are at least two of these units on the market now, with more likely to come in the future.

Q: In emergency situations where cable or satellite television reception goes out in an emergency, but AC power still exists to operate television sets, what can be done to watch television for emergency news?

One thing that can be done to have a backup system in place is to purchase one converter box and a suitable antenna in order to pick up some local free, over-the-air DTV channels until the cable signals are restored. Of course, a side benefit is that any local DTV channels that are not carried on the cable system might be receivable.

Other alternatives are handheld battery-operated AM/FM radios that will provide emergency information when needed. Also, some TV stations simulcast their broadcasts on local radio stations. Finally, the National Oceanic and Atmospheric Administration (NOAA) recommends the purchase of a NOAA Weather Radio, available at many electronic and department stores. NOAA Weather Radio provides 24/7 continuous weather information, and alerts listeners immediately to life-threatening local severe storm warnings, the latest hurricane advisories from the National Hurricane Center, and the Hurricane Local Statements from the National Weather Service. More information can be found at: www.srh.noaa.gov/mfl/radio.php.

Q: Will digital television stations continue to provide emergency alerts?

Yes, they will. DTV stations are required to continue operating the Emergency Alert System (EAS). For more information, go to: www.fcc.gov/cgb/consumerfacts/eas.html.

Q: Will digital television still allow parental controls such as V-chip?

Yes, it will. The same V-chip technology required in analog television is also required in digital television so that parents can block unwanted programming from being viewed by their children. It works by reading the digital rating information about each program to decide if it is has been allowed by the parent’s selections.

More about V-chip and the ratings system can be found at: www.fcc.gov/vchip.

COUPON ELIGIBLE CONVERTER BOX (CECB) PROGRAM

Q: Is there some federal subsidy program that can be used to offset the cost of these converter boxes?

Yes, Congress created a TV converter box *coupon* program (Deficit Reduction Act of 2005 that is part of the Digital Television Transition and Public Safety Act of 2005) for households that want to continue using their legacy analog sets *after* February 17, 2009 when the full-power analog signals are turned off. Congress selected the U.S. Commerce Department's National Telecommunication and Information Administration (NTIA) to be in charge of administering this coupon program that allows *two* \$40 coupons to be given on a first-come, first-served basis to every *eligible* household. These coupons will defray the cost of purchasing up to two NTIA-*certified* digital-to-analog (D/A) converter boxes at NTIA-*certified* electronic retail outlets ("brick and mortar" stores as well as online and phone line stores).

These eligible converter boxes typically cost anywhere from \$50 to \$70 *before* the \$40 coupons are applied. More information on this coupon eligible converter box (CECB) program can be found at: www.ntia.doc.gov. A list of certified *converter boxes* (with manufacturers and model numbers) can be found at: www.ntiadtv.gov/cecb_list.cfm. A list of certified *retailers* can be found at: www.dtv2009.gov/VendorSearch.aspx.

Q: What are these coupons?

Coupons, which are *red* plastic cards similar to credit cards or gift cards that are widely used in the retail industry, are available from the government as supplies last (i.e., as long as the government-provided money is still available). These coupons contain specific information:

Name

Address

Reference Number

Coupon ID

Expiration Date

Coupons are worth \$40, but they do *not* carry a "stored value" (like a gift card that keeps a running total of funds spent). *Each* coupon can only be used towards the purchase of a *single* NTIA-*certified* DTV converter box. The intent of the program is to allow consumers to continue to view over-the-air television on the same TV set that they used prior to the transition, but *not* to enable upgrades in technology such as HDTV viewing or electronic storage (e.g., digital video recording).

Q: Who is eligible to receive these coupons?

Every household is eligible to receive up to *two* \$40 coupons toward the purchase up to two eligible converter boxes, but coupons supplies are limited by the amount of funding that Congress appropriated to the NTIA (\$1.5 billion, *including* administration of the coupon program). There are 22.25 million coupons that are available to *all* households. If these are used up, then another 11.25 million coupons are available to *only* households that *solely* rely on over-the-air television broadcasts via an antenna (i.e., households that have at least one TV set connected to subscription services such as cable, satellite, or telephone are *not* eligible for this second batch of coupons).

Under the program regulations, a surrogate can apply for a coupon for someone who is unable, but will need to use that person's home address, which will be validated for eligibility. The same two coupons per household limit will still apply, and the coupons are intended for the resident of that household. Also allowable under program regulations is giving coupons for *free* to a family member, friend, or neighbor.

However, **under no circumstances can anyone legally sell, duplicate, or tamper with any coupons.**

Q: Are nursing homes, group homes, and other institutions eligible for coupons?

Initially, they were not eligible. However, in April of 2008, the NTIA filed a proposed rulemaking that would allow these various groups to be included in the coupon program. The final decision was to allow nursing home residents to participate in the program.

Q: When can these coupons be requested?

These coupons became available on January 1, 2008 and will continue to be available through March 31, 2009 as supplies last (i.e., the federally-mandated amount of money has not been depleted). Up to 1.5 billion dollars, if needed, was allocated by the government (i.e., Congress) to administer the program and cover the cost of coupons, all of which came from the revenue earned by auctioning off most of the freed spectrum that the transition from analog to digital has provided.

The coupons must be redeemed within 90-days of their mailing (expiration date is on the front of the card) or they expire (i.e., use them or lose them). Two coupons can be requested *together* or they can be requested *separately* one at a time.

Q: How can one apply for coupons?

Interested parties have several means to request coupons:

Call 1-888-DTV-2009 (1-888-388-2009).

Apply online at www.DTV2009.gov.

Mail a coupon application to P.O. Box 2000, Portland, OR 97208-2000.

Fax a coupon application to 1-877-DTV-4ME2 (1-877-388-4632).

Deaf or hard of hearing callers may dial 1-877-530-2634 (English/TTY) or 1-877-495-1161 (Spanish/TTY). TTY service is available from 9 AM – 9 PM Eastern Time, Monday through Friday.

Some retailers will make *applications* available to interested parties, but they **cannot** provide the coupons themselves as only the government can do that.

Q: What information is required by the government in order to request these coupons?

The government only requires minimal information from the consumers:

- 1) Name
- 2) Household address
- 3) Number of coupons requested (one or two)
- 4) Whether the household subscribes to cable, satellite, or some other subscription TV service

The government will *not* use your name and address for any other purpose than administering the NTIA coupon program, per the protection under the privacy laws.

Q: When will the coupons arrive in the mail?

Consumers who apply for coupons will receive them in the mail. The date that they arrive will depend on the date when the application was submitted. The status of the coupon arrival date can be checked by going online at www.DTV2009.gov/CheckStatus.aspx, and entering the reference number, coupon ID, or name and address on the appropriate form on the same Web page. Allow at least *three* weeks after applying before checking the status of the coupon arrival. **It is expected that those who wait until near February 17, 2009 will experience much longer waiting times for coupons.**

Note that coupons expire in 90 days after the mailing date (check the expiration date on the coupon), and the law currently states that these coupons cannot be replaced if they expire, or they are lost or stolen.

Q: Where can these DTV converters be purchased with these coupons?

Participating electronic retailers nationwide are selling NTIA-certifiable TV converter boxes in their *stores, online, and by telephone*. However, only participating *certified* retailers (as determined by the NTIA) are eligible to sell these units with coupons. The coupons can be used by anyone in the eligible household, but only two coupons per *household* are allowed. The coupons must be used at the point of sale and must be redeemed at the time the TV converter boxes are purchased. Currently, coupons expire 90 days after they are mailed (not when requested or when received), with no recourse to replace them.

Once used, the coupons are immediately deactivated so that they can not be used again. If coupons are lost or stolen, they can not be replaced by law. Both the receipt and a record of the unique coupon number should be kept in the event that the box is exchanged or returned.

A list of certified retailers (stores, online, phone) in a viewer's area is supplied with the coupons when they arrive in the mail. For more information on certified retailers, visit: www.dtv2009.gov/VendorSearch.aspx.

Q: What is meant by an "eligible" TV converter box?

The word eligible refers to the mandated NTIA requirements that the converter box must meet. Therefore, TV converter box models that are sold as part of the government-subsidized coupon program must meet technical *features* and *performance* standards determined by the NTIA who is administering and overseeing the program.

The RF performance requirements help to guarantee consistent and acceptable DTV reception in most locations, assuming that the entire receive system (antenna type and location, feedline cable type, any splitters or amplifiers, and converter box) is acceptable. The required features help to guarantee success in navigating the digital channels to take advantage of the new digital television technology.

A list of the eligible coupon eligible converter boxes (CECB) can be found at: https://www.ntiadtv.gov/cecb_list.cfm. A list of the technical specifications regarding features and RF performance can be found at: www.ntia.doc.gov/dtvcoupon/DTVmanufacturers.pdf.

Q: Towards what products can these coupons be applied?

These coupons can *only* be used to purchase NTIA-*certified* boxes that meet mandated RF reception performance specifications as well as mandated features, not just any set-top converter box. These coupons CANNOT be used to purchase other types of DTV receivers, such as HDTV or DVR units or any other consumer electronics devices, nor can they be applied toward the rental or purchase of cable or satellite set-top boxes. The intent of the program is to allow consumers to continue to view television over-the-air on the same TV they used prior to the transition, but not to enable upgrades in technology.

Q: Can two coupons be applied towards one certified converter box?

No, only one coupon can be applied towards each converter box. Two coupons cannot be combined to be applied towards one unit, nor can they be used towards the purchase of other DTV products. Therefore, a maximum of two converter boxes in a household can be subsidized by the NTIA coupons.

Q: Can a converter box be returned for exchange or credit?

If a store permits exchanges or credits, a box may be *exchanged* for another converter box, with cash or credit returned for only the amount *beyond* the cost of the \$40 coupon. No cash or credit can be received for the \$40 coupon itself.

If a box is returned to the store (with no exchange), the only amount refunded by cash or credit is the amount spent *beyond* the cost of the \$40 coupon (i.e., only the amount spent out of pocket). No refunds on the actual \$40 portion that the coupon provides are allowed, and the coupon used to buy that converter box *cannot* be returned.

Q: How can the features of various certified converter boxes be determined in advance of their purchase?

Some converter box features are *mandated*:

- Minimal program guide

- Virtual channel tuning

- RF input on panel-mounted female F-connector

- Selectable CH 3 and CH 4 RF output on panel-mounted female F-connector

- Composite baseband video and audio outputs using color-coded female RCA jacks

- On-screen channel display

- Owner's manual at least in English

- Front panel-mounted LED power indicator

- On-screen signal quality indicator

- Closed captioning

- Emergency Alert System (EAS) compatible

- V-CHIP parental control capability

Other features are *optional*, and may vary with manufacturer and model number. Comparisons of some converter box models are available at:

www.consumerreports.org/cro/electronics-computers/televisions/digital-tv-converter/overview/dtv-converter-box-guide.htm

en.wikipedia.org/wiki/Comparison_of_CECB_units

www.fcc.gov/cgb/consumerfacts/converterboxfeatures.html

Q: What are the important things to know about the coupon program?

A summary of the things to remember about the coupon program:

This is a *one-time* cost for the converter hardware, with **no** subsequent monthly service charge.

Only two coupons per eligible household are allowed, and must be requested from the government by phone, fax, mail, or Internet.

Coupons will come in the mail, and have expiration dates printed on them (i.e., “use them or lose them”).

Consumers can buy as many converters as they want, but only two converter units can be purchased with government coupons (one coupon for each converter, with no combining of coupons for a single converter).

Coupons CANNOT come from the retailers, but only from the government. However, retailers may provide consumers with *application* forms.

Coupons have no *cash* value (but are usable only to defray the cost of a converter box).

The coupons can only be applied towards the cost of the converter unit itself, and *not* towards any taxes (local, county, state, etc.).

Coupons cannot be used for converter boxes *already* purchased, but can only be used at the point of sale with coupons redeemed at time of purchase.

Two converter boxes can be bought in a single transaction as long as two valid coupons are used.

Boxes can *not* be returned for \$40 cash back if a coupon was used, just the amount of out-of-pocket money paid (i.e., the amount beyond the \$40 coupon value).

Coupons should **never** be purchased since they are *free* (a maximum of two) from the government.

It is *illegal* to sell the coupons, but they can be given to a family member or friend.

Ignore any offer for a “free” converter box, especially if it requires payment for shipping or a warranty. These companies are not certified by the government and their converter boxes are not eligible for the coupon program (and it may cost more for the consumer in the end).

Q: Where can more information on the NTIA coupon program be found?

There are some other specific requirements, and an easy way to request these coupons. Interested parties can call the NTIA at **1-888-DTV-2009** or visit the NTIA website to get more information and request coupons: www.DTV2009.gov.

A list of certified boxes can be found at: www.ntiadtv.gov/cecb_list.cfm.

A list of certified electronic retailers can be found at: www.dtv2009.gov/VendorSearch.aspx.

DTV SPECTRUM ALLOCATION

Q: Do digital television signals currently use the same frequency band as the analog television signals?

Yes, both analog and digital stations *currently* transmit their respective signals over the public airwaves in the low-VHF band (CH 2 – CH 6), the high-VHF band (CH 7 – CH 13), and the UHF band (CH 14 – CH 69). [Note that VHF stands for very high frequency and UHF stands for ultra high frequency.] This is why both analog TV and digital TV signals can be picked up by the same all-band antenna (VHF and UHF). These are three distinct frequency bands, and have been used throughout the analog television history, starting with the VHF band in the 1940s and the UHF band being added in the 1950s.

However, it is very important to realize that for quite some time the FCC planned to reduce the amount of television spectrum starting on February 17, 2009 when the full-power analog stations are turned off. This is possible because of the increased efficiency of the new ATSC digital television system. This new “core” spectrum will be from CH 2 through CH 51, inclusive, thereby freeing up much needed spectrum (CH 52 – CH 69) for new communication uses. Some of the soon-to-be-available freed spectrum has been designated for emergency first responders (police, fire, paramedic, etc.). The rest of this freed spectrum has been auctioned off to communications companies to use for their new data services to be offered to the public. This spectrum auction has brought into the United States Treasury significant amounts of money, some of which is being used to pay for the current converter box subsidy program overseen by the NTIA.

Q: What are the basic advantages and disadvantages of using each television band?

The **low-VHF band** (CH 2 – CH 6) utilizes 54 – 88 MHz, and resides just below the FM radio band. It requires lower signal power to be transmitted, but requires a large television antenna to be received. The electromagnetic waves used to carry a television signal in this band from the transmitter to the viewer’s television set have long wavelengths (≈ 14.2 feet), and it is this fact that requires the television receive antennas to be larger. Its propagation characteristics are such that these waves can bend around the curvature of the earth reasonably well, and can therefore cover more area and reach more people. But this can also be a negative if far away television signals travel into other television stations’ coverage area and cause interference. Also, impulse noise from electrical machinery with motors is common in this low-frequency band, and it can significantly interfere with television signals in this band.

The **high-VHF band** (CH 7 – CH 13) utilizes 174 - 216 MHz. It requires moderate signal power to be transmitted, and requires only a moderately-sized television antenna to be received. The electromagnetic waves used to carry a television signal in this band from the transmitter to the viewer’s television set have moderate-length wavelengths (≈ 5.1 feet). Its propagation characteristics are such that these waves can bend around the curvature of the earth somewhat, and can therefore cover a little more area and reach some more people. Impulse noise from electrical machinery with motors is *not* as common in this band, and it therefore does not significantly interfere with television signals in this band.

The **UHF band** (CH 14 – CH 69) utilizes 470 – 806 MHz. It requires large signal power to be transmitted, and requires only a small-sized television antenna to be received. The electromagnetic waves used to carry a television signal in this band from the transmitter to the viewer’s television set have short wavelengths (≈ 1.6 feet). Its propagation characteristics are such that these waves cannot bend very well around the curvature of the earth, and can therefore cover the least area, although the large transmitter power can make up for *some* of this lost area. Impulse noise from electrical machinery

with motors is not common at all in this band, and therefore it essentially does not interfere with television signals in this band.

Q: Are all the digital stations using different channels from their analog channels, and if so, why?

All eligible analog television stations were allocated a 2nd separate TV channel in the existing television spectrum back in 1996 (with some slight altering of this channel allocation plan in 1997). A broadcaster *cannot* simultaneously use the same channel in his service area for both analog and digital signals, therefore the allocation of a separate (i.e., 2nd) channel was needed, with the understanding that this second channel was to be returned to the government at the end of the transition period (i.e., analog shutoff), now scheduled for February 17, 2009. It is important for DTV viewers to know what actual channels are currently being used for analog and digital television *before* the end of February 17, 2009, and what actual channels will be used for digital television *after* February 17, 2009 in order to determine if their current antenna might be acceptable for digital reception, or what type of new antenna might need to be purchased.

Q: Are all digital stations on UHF channels?

No, they are not. However, *most* of them are on UHF channels (14-69) during the transition because that was where there was the largest amount of free spectrum to “squeeze” in the DTV signals on previous taboo channels between the existing analog signals. Likewise, most DTV signals will be on UHF after February 17, 2009 when the full-power analog signals are turned off. Very few DTV stations in the country use low-VHF channels (2-6) now, and even fewer after February 17, 2009 since this is not an optimum frequency band to use. However, there will be a fair number of high-VHF DTV channels (7-13) after February 17, 2009.

Q: If TV stations are currently using a different television channel to transmit DTV, then why does a viewer select the same channel number as the analog channel, except with a “-1” after it?

The current digital television standard, named after the **A**dvanced **T**elevision **S**ystems **C**ommittee (ATSC), calls for all digital television channels to use a “[virtual](#)” channel description methodology. That is, the DTV *major* channel is referenced to its analog channel, but with a different *sub-channel* number for digital programs. For instance, if the analog station is on CH 5, then the analog channel is tuned by selecting CH 5-0 while the digital channel (regardless of what actual RF channel is being used) is referred to as CH 5-1 or CH 5-2, etc.

Q: What is a virtual channel?

A virtual channel is a simplified tuning method for the television viewer that allows a station’s original analog channel number to be used for tuning its companion digital channel during the transition when the analog channel is still available as well as after the end of the transition when the analog signal is turned off. The two channels are distinguished by defining the analog channel with a “-0” and the digital channels (or sub-channels) as “-1”, “-2”, etc. As an example, analog CH 9 is defined as “5-0”, while the digital sub-channels are defined as “9-1”, “9-2”, etc.

This is accomplished by a method similar to telephone call forwarding, where the telephone user programs in a new phone number to the telephone that redirects all calls to this new phone number. The caller has no idea that the call has been transferred to the new number, and does not need to know the forwarded phone number, just the old phone number. After a DTV receiver scans all the possible channels in the television spectrum to find any digital signals, it reads special data in every digital

channel that it can decode and stores this information in a large look-up table. Then, when the viewer enters a *virtual* channel to be tuned, the DTV receiver knows which *actual* channel that should be tuned (i.e., it forwards it to the actual digital RF channel).

Q: How can the actual DTV channels be determined from knowing the virtual channels?

There are two sets of tables that describe *actual* analog and digital channel assignments. One describes the full-power analog and digital channels *before* February 17, 2008. The other describes the digital channels *after* February 17, 2009 (i.e., after full-power analog stations shut off). It must be noted that the FCC has allowed some leeway for broadcasters to help them in these last days of analog television. Some stations are turning off their analog signals early, before February 17, 2009. Others will wait until February 17, 2009. Some will be changing actual RF channels after February 17, 2009 while others will remain on their present digital channels.

Channel information describing status *before* and after February 17, 2009 can be found at:
www.antennaweb.org.

PROPAGATION FUNDAMENTALS

Q: How do the television signals get to a viewer's house?

TV signals are transmitted through the air as electro-magnetic waves at the speed of light (3×10^8 m/sec or 186,000 miles/sec). These electromagnetic waves consist of two parts: an *electric* field and a *magnetic* field. As the wave propagates, these two components are always situated at right angles to each other. If one assumes a hypothetical isotropic *point source* of energy that radiates in all directions, the TV signal can be thought of as a series of wave fronts in the shape of a sphere. As the signal propagates through the air over distance “r” (i.e., the radius of the sphere), the sphere gets larger and larger. Any receive antenna that is in the propagation path has an effective area that collects the signal. However, the *surface area* of the spherical wavefront (which represents the total energy transmitted by the point source) gets larger and larger as the distance between the transmitter and receiver increases (i.e., $4\pi r^2$), and therefore the signal energy that can be collected by the receive antenna gets smaller and smaller.

Therefore, if a viewer moves farther away from the transmitter, the signal power decreases by the inverse of the distance squared (i.e., $1/r^2$). This is referred to as the inverse square law. What this means is that if one viewer lives 5 miles from the transmitter and receives a certain signal level, then another viewer with identical propagation conditions and the same exact type of antenna at 10 miles from the transmitter (i.e., twice the distance), would receive a weaker signal that is only one-fourth the signal power as the first viewer. At 20 miles from the transmitter, the viewer there would get one-sixteenth the signal level as that received at 5 miles from the transmitter. This all assumes ideal propagation conditions, such as a line-of-sight path between the transmit antenna and the receive antenna, and no terrain or man-made obstructions. However, it does show how fast the signal level decreases with distance.

Knowing this information may help a viewer decide what type of antenna to use, and what kind of DTV reception might be expected. Note that *some* real-world antennas have their amplification gain expressed relative to the isotropic point source antenna, in logarithmic terms of dBi (larger values of dBi mean larger antenna gain).

Q: What are transmit and receive antennas really like since a point source is not practical, but only theoretical?

Dipole antennas are the simplest and most practical antenna element to consider. They essentially consist of two rods (end-to-end) that develop a voltage between them when in the electro-magnetic signal path of a desired television station. This is important to know since many receive antennas that a viewer might consider buying are made up of various *combinations* of these simple basic dipole elements, the multiple combination of these elements giving the antenna *both* gain and directivity.

The dipole pattern is *not* omni-directional (i.e., circular pattern), but rather has a figure-eight shape with the major lobes in each direction that is perpendicular from the dipole. While this type of antenna is not uni-directional (i.e., with a major receive lobe in one direction), it can be considered essentially bi-directional (i.e., with two equal major receive lobes, one in the “front” and one in the “rear”). Each lobe can be considered to have gain with respect to the hypothetical point source antenna. Note that the dipole antenna does not receive any signals off the “ends” of the antenna.

Knowing this information may help a viewer decide what type of antenna to use, and what kind of DTV reception might be expected. Note that *some* real-world antennas have their gain expressed relative to the dipole antenna, in logarithmic terms of dBd (larger values of dBd mean larger antenna gain).

Q: What is signal polarization and how does it affect DTV reception?

Polarization is simply the orientation of the electric field with respect to the ground. Since the electric and magnetic fields in a propagating electromagnetic wave are always at a right angle orientation, if one of them is transmitted horizontal to the ground, the other will be vertical with respect to the ground.

All broadcast television signals are transmitted as *horizontal* polarization (AM and FM radio are transmitted as *vertical* polarization). [NOTE: In some special cases, a broadcaster is allowed to use circular polarization (CP), which is a combination of both horizontal and vertical polarization in a special time phase relationship.] This means that a dipole antenna that is receiving these horizontally-polarized television signals should be placed parallel to the ground. Likewise, more complex antennas with multiple dipole antennas arranged optimally for directivity and gain, should be also placed parallel to the ground.

It should be understood that as signals bounce off objects, they can actually experience rotation of their polarization (i.e., they become de-polarized). Therefore, indoor reception, which often encounters large amounts of signal reflections, can experience severe signal de-polarization. Experimentation with tilting the indoor antenna can help to determine the best configuration for good DTV reception.

Q: Do all TV stations transmit their signals in all directions with an omni-directional antenna?

No, although many of them do. There are cases where a station desires to shape its transmit pattern so as to not provide signal coverage in areas with little or no population (e.g., over a large lake or behind a mountain). In other cases, the FCC requires a station to shape its transmit pattern to minimize signal propagation in a certain direction in order to avoid unacceptable interference into a different station's service area.

Knowing this situation may help a viewer understand why certain signals from some TV stations might come in better or worse than from other stations. Sometimes the use of transmit antenna pattern shaping to avoid interference might only apply to some of the local channels since interference is channel specific, and depends what channels are being used in nearby markets. Check with local broadcasters for this information.

Q: What does the term wavelength mean?

Wavelength (λ) is the distance (in inches or feet) between the peaks of a propagating wave of a given frequency, and is directly proportional to the speed (v) of the electro-magnetic wave and inversely proportional to the signal frequency of the propagating wave (i.e., $\lambda = v / f$ where v is the velocity of light in a vacuum = 3×10^8 m/sec and f is the signal frequency in Hz). Signal propagation speed in air is considered to be constant, and, therefore, this means that as the frequency of the DTV channel increases, the wavelength decreases.

Knowing the approximate wavelength for the DTV signals desired to be received can be useful to understand DTV reception. Signals with long wavelengths (e.g., Low-VHF) require larger antennas than those with short wavelengths (e.g., UHF). Also, signal levels can vary (i.e., fade) within a wavelength in receive locations where multiple versions of the same signal are present, which means that UHF signals can experience more potential signal fading over shorter distances than VHF.

Q: What is multipath (i.e., “ghosting”), and why is it important?

Ideally, there should only be one propagation path between the transmitter and the receiver for best performance (i.e., a direct path). However, in reality, there is often more than one propagation path, with the television signal bouncing (i.e., reflecting) off naturally-occurring objects such as mountains, hills, bodies of water, etc. as well as man-made objects such as buildings, bridges, water towers, etc (i.e., indirect paths). Each propagation path has its own propagation signal level attenuation and distance, causing the signal to vary in amplitude and delay, possibly in a time-varying manner. It is not always easy to accurately predict the severity of the multipath effects from a given object as it depends on its distance from and terrain between the transmit and the receive locations, the shape and effective area of the reflecting object, and the direction that the reflecting object faces. Also, reflecting objects may not reflect all television channels (i.e., frequencies) equally.

As the main signal and all of the delayed echo signals all arrive at the receive antenna, they combine together either constructively (enhance one another) or destructively (cancel one another). For analog receivers, these extra signals cause additional images plus the main image to be seen on the screen, and these extra images are referred to as “ghosts.” In DTV, these echoes, if severe enough, can cause data errors and disruption of the video and audio.

The sensitivity of the combined signals depends on how each path length varies over time. For instance, if the transmitter tower is swaying in the wind (e.g., tall building like the Sears Tower in Chicago), then all the various echo propagation paths will vary. If only the building that is reflecting one of the echo paths is swaying in the wind, then only that one indirect path will vary. Remember that if the echo path length (distance) varies by a significant fraction of one wavelength, significant changes in the received signal can occur. Therefore, UHF television signals with shorter wavelengths may experience more multipath-induced time variation than VHF.

Q: What structures *might* cause television signal multipath (i.e., “ghosting”)?

Any large building that is as tall as or taller than the receive antenna or that blocks the receive antenna’s view of the transmitter may cause noticeable reflections. Some buildings to consider as potential reflectors are:

- Church steeples
- Apartment/condominium buildings
- School or office buildings
- Industrial or warehouse buildings
- Water towers
- Large communications towers (e.g., TV or radio)
- High tension power lines and towers

Not all man-made structures will cause multipath due to the large number of variables involved. Nearby buildings, especially wood frame houses, that are not taller than the receive antenna typically do not cause significant reflections. Likewise, streetlight or utility poles, cellular or PCS towers, or ham and other TV antennas typically do not reflect television signals.

Note that trees and foliage typically do not cause reflections, but may absorb (and thus attenuate) some of the signal as it travels through them. This absorption by the foliage may vary with the amount of

moisture present and also with the presence or absence of leaves. Therefore, having an attenuation located away from heavy foliage if possible and preferably above most of it would be better.

ANTENNAS

Q: Are outdoor television antennas prohibited in some communities or in some apartment or condominium complexes?

No, they are not. One part of the Telecommunications Act of 1996 (Section 207) allows outdoor terrestrial broadcast antennas to be erected and used by over-the-air viewers, assuming the viewer follows some basic guidelines. This legislation is the same that allows satellite dishes to be placed on rooftops and other appropriate areas.

The FCC, per direction from the Telecommunications Act of 1996, adopted the Over-the-Air Reception Device Rule concerning governmental and nongovernmental restrictions on a viewer's ability to receive video programming signals from direct broadcast satellites ("DBS"), multi-channel multipoint distribution systems ("MMDS"), or television broadcast stations ("TVBS"). This rule, which is cited as 47 C.F.R. Section 1.4000, has been in effect since October 14, 1996. It specifically prohibits restrictions that impair the installation, maintenance, or use of antennas used to receive video programming. The rule applies to video antennas including direct-to-home satellite dishes that are less than one meter (39.4") in diameter, wireless cable antennas, and TV antennas. The FCC rule prohibits most restrictions that: (1) unreasonably delay or prevent installation, maintenance, or use; (2) unreasonably increase the cost of installation, maintenance, or use; or (3) preclude reception of an acceptable quality signal.

The rule applies to viewers who place video antennas on property that they own and that is within their exclusive use or control, including condominium owners and cooperative owners who have an area where they have exclusive use, such as balcony or patio, in which to install the antenna. The rule applies to town homes and manufactured homes, as well as to single-family homes.

However, the rule does allow local governments, community associations, and landlords to enforce restrictions that do not impair video reception, as well as restrictions needed for safety or historic preservation. In addition, the antenna prohibition rule does not apply to common areas that are owned by a landlord, a community association, or jointly by condominium or cooperative owners. Therefore, restrictions on antenna installed in common areas are enforceable.

On November 20, 1998, the FCC amended the rule so that it applies to *rental* property where the renter has exclusive use, such as a balcony or patio beginning on January 22, 1999.

A summary of these rules can be found at: www.fcc.gov/cgb/consumerfacts/consumerdish.html and www.fcc.gov/mb/facts/otard.html.

Q: Is an antenna still needed to receive over-the-air DTV signals?

Yes, an antenna is still needed for DTV reception since there typically is no built-in antenna present in most DTV receivers, and definitely not in NTIA-certified converter boxes. It is no different from analog television reception in that an antenna (indoor or preferably outdoor) is required to pick up the off-air signal and deliver it to the converter box or DTV receiver. In general, a similar type of antenna that provides *good* analog television reception can be used for DTV, assuming that the antenna covers the same television band that both the legacy analog and new digital signals use and that the television station hasn't placed the digital transmitter site in a significantly different location than the analog transmitter site.

For those viewers living in a home or apartment/condominium, there may be an antenna on the roof that distributes the television signals throughout the building. This is called a master antenna television system (MATV). Assuming that this antenna and distribution system is properly operating (and able to receive the proper television band), this would be the best situation for reliable DTV reception. If an indoor antenna provides reasonable analog television reception, then it may provide DTV reception. However, if there is the opportunity to place an antenna on the roof or in the attic (assuming there is no metal roof), that would allow the *best* chance of reliable DTV reception.

After February 17, 2009, *some* (not all) television stations will be moving their actual digital RF channel to a new channel, and perhaps even a new television frequency band, from where it is now (either back to the analog RF channel after it is turned off or to a new RF channel completely). This is the reason that a channel scan is required so that these new channel allocations can be detected by the DTV receiver and stored in memory for proper DTV tuning. This *may* require a change of the viewer's receive antenna, unless it is a properly functioning all-band antenna that covers all three television bands well (low-VHF, high-VHF, and UHF). Check with www.antennaweb.org to determine what type of antenna might be required for reliable DTV reception.

Q: Is there such a thing as a *digital* antenna or an *HDTV* antenna?

No, not really. While the box in which the antenna is sold may say “DTV Antenna” or “HDTV antenna”, the analog and digital television signals share the same frequency bands (low-VHF, high-VHF, and UHF) and therefore can be picked up (i.e., received) with the same antenna.

However, a viewer may need a new antenna should the existing antenna not be designed for the entire television frequency band (e.g., VHF only antenna, where analog signals might currently reside in a given market, but where digital signals may reside in the UHF band).

Another possibility is that the existing antenna may be providing very noisy analog pictures (e.g., due to degraded performance from years of weather abuse), but the digital signals must be above the “magic” threshold to get perfect, clean pictures and sound, and therefore a higher-gain antenna might be needed. Therefore, it is important to know the actual channels that are being used for DTV in order to select the best antenna for the job.

One way to find out what DTV channels are available in a given market before and after February 17, 2009 is to go to: www.antennaweb.org.

Q: What general types of antennas are best to use for DTV reception?

Just as for analog television reception, a good outdoor antenna is the *best* option, an attic antenna (if there is not a metal roof) is the next best option, and the last option that should be considered is an indoor antenna.

Not all antennas on the market are designed to cover all three television bands. Some are VHF only (CH 2 – CH 13) while others are UHF only (CH 14 – CH 69). Some *individually* cover the upper VHF band (CH 7 – CH 13) and the UHF band (CH 14 – CH 69). Yet others cover *all* three television bands (CH 2 – CH 69), and are referred to as all-band or “combo” antennas. It is important to know what television bands the antenna can receive in order to determine if it can be used to receive DTV stations transmitting on their current transition channel *before* February 17, 2009 or on their post-transition channel *after* February 17, 2009 (since some DTV stations might be changing their actual DTV RF channel).

After the transition from analog to all-digital transmission ends, the same antenna that currently provides acceptable analog reception *may* also provide acceptable DTV reception. However, this is not guaranteed. To determine which type of antenna is required and what actual DTV channels are currently in use, go to www.antennaweb.org. More information can be found at: www.fcc.gov/cgb/consumerfacts/dtvantennas.html.

Q: What specific techniques can a viewer use to determine if their *current* television antenna is acceptable for digital reception or whether a new antenna is required?

In general, the message that has been widely shared in the past is that if a viewer's current terrestrial broadcast antenna (outdoor or indoor) provides good or excellent analog reception quality (i.e., decent pictures and sound that were subjectively determined to be only slightly annoying), that antenna *should* be acceptable for DTV reception. However, this is easy in concept, but may not be quite as easy in practice due to several caveats. It really depends if: (1) the new digital signals are in the same television *frequency bands* (VHF or UHF) as the analog stations that are being watched, so that they have similar propagation characteristics; (2) the digital signals are coming from generally the same transmitter *locations* and experiencing the same terrain on the path to the receiver, (3) the DTV signals are being transmitted at their *full allocated power*; and (4) the receive antenna is designed to receive signals in the television bands utilized by the DTV signals. These facts can be determined by performing a little personal research, by obtaining this information from the local broadcasters, or by going to: www.antennaweb.org.

The simplest way for a viewer to determine the quality of the signals at the input to their DTV sets is to use a piece of "test equipment" that every over-the-air analog viewer has in their home called the analog television set! The analog TV can be thought of as the "window to the RF world", which means that the quality of the analog picture reveals on the television screen any impairments or any interference present at the viewer's antenna outputs.

For instance, viewers can easily identify weak signals by a snowy picture, impulse noise from motorized devices in the home (e.g., vacuum cleaners, popcorn poppers, etc.) as white speckles on the screen, "ghosted" signals (due to signal reflections off of objects in the signal propagation path) as multiple images shifted horizontally on the screen, and interference from other analog signals as diagonal stripes on the screen.

To determine if an existing antenna is acceptable for DTV reception, the analog television can be tuned (*before* February 17, 2009) to a full-power analog channel that is near the *actual* desired DTV channel both in frequency and in transmitter location to see if you can get a decent signal through your home receive system (i.e., antenna, *optional* preamplifier, cable, splitters, etc.). To help in this determination, a viewer can identify in the analog picture (1) weak signals if they see snow, (2) impulse noise if they see white speckles, (3) multipath if they see multiple "ghosted" images, and (4) interference if they see diagonal stripes on the screen. If *reasonable* pictures and sound are not possible, a new antenna *might* be required for reliable DTV reception.

Q: Are all digital stations on UHF channels?

No, they are not. However, most of them are on UHF channels (14-69) during the transition because that was where there was the largest amount of free spectrum to "squeeze" in the DTV signals between the existing analog signals. Likewise, most DTV signals will be on UHF after February 17, 2009 when the full-power analog signals are turned off. Very few DTV stations in the country use low-VHF channels

(2-6) now, and even fewer after February 17, 2009 since this is not an optimum frequency band to use. However, there will be a fair number of high-VHF DTV channels (7-13) after February 17, 2009.

Therefore, antenna selection must be done carefully, basing it on the *actual* DTV RF channels that are in use.

Q: What *general* things should be considered when selecting an antenna?

Good TV antenna selection is *not* based solely on distance from the television station's transmitter site. *Both* analog and digital reception depends on accurately (1) characterizing signal propagation conditions and (2) selecting appropriate receive system components.

Signal propagation conditions involve not only the transmit and receive antenna locations, the distance between them, and their heights above ground level, but also the terrain in between the two.

Signal components involved at the receive site are the antenna, cable feedline, *optional* amplifiers (e.g., mast-mounted preamplifiers or indoor distribution amplifiers), splitters, and DTV receivers.

Q: What *specific* things should be considered when purchasing a new receive antenna for DTV reception?

If a viewer knows that there will be no VHF (2-13) DTV signals after February 17, 2009, then a smaller UHF-only (14-69) antenna may be the most desirable. However, if it is determined that there will be high-VHF (7-13) in addition to UHF digital channels, then a high-VHF/UHF combo antenna (7-69) would be best, which is still smaller than a complete VHF/UHF combo antenna (2-69).

Another consideration is the direction from which all of your desired TV station transmitters are located. If they are all coming from one direction, then a directional antenna may be the best choice. If the distance to these commonly located transmitters is far away (e.g., > 30 miles), a higher gain directional antenna might be more appropriate with low-loss coaxial cable. And, if the distance from the transmitters is very great (> 50 miles), a high-gain, directional antenna with a built-in or external preamplifier feeding low-loss coaxial cable might be called for.

If the television transmitter towers are in more than one group that are in different directions from the viewer, either multiple antennas summed carefully together might be effective or a lower gain omnidirectional antenna is another possibility. A situation such as this, but at much farther distances from the transmitter may again require additional preamplifier gain directly at the output of the antenna.

To determine the distance and direction from the various transmitter sites, and actual RF channels of the DTV signals, go to: www.antennaweb.org.

Q: Are “rabbit ears” indoor antennas good for receiving all DTV channels?

No, they are not. “*Rabbit ears*” antennas are inexpensive to purchase and easily manipulated for adjustment of the best VHF signals. However, they are not the best for UHF reception, as either simple *loop* or *bow-tie* antennas perform better at these higher DTV channels. Nevertheless, all of these simple indoor antennas have been around for more than 40 years, and they are known primarily for one thing: low cost.

None of these old legacy antennas are necessarily optimum for any kind of television reception, especially DTV reception. Much better indoor antennas have been designed in recent years. However, as expected, they are not as inexpensive as rabbit ears, loops, or bow tie antennas. Of course, whenever possible, an *outdoor* antenna should be used to provide the best chance of reliable DTV reception.

Q: Is there some help that is available to help select a consumer antenna?

A viewer with Internet access can visit the following website: www.antennaweb.org.

This website allows a viewer to type in their address and zip code to see what possible DTV channels might be received, their call letters, their virtual and actual channel numbers, and the direction (with respect to north) from their homes that their antenna should be pointing.

It also accounts for the local *terrain* between the transmit and receive antennas by using two data sources (USGS and NASA's shuttle radar terrain mapping project). This is important since most television signals primarily require line-of-sight since they don't bend well with the curvature of the earth like lower-frequency AM radio signals. Therefore, naturally-occurring obstructions (mountains, hills, and trees) as well as man-made structures (buildings, bridges, water towers, etc.) can partially or totally block signal propagation or even reflect the signal giving rise to multiple signal paths (i.e., multipath or "ghosting"). Many propagation programs do not account for local man-made structures. However, using an exact address location (rather than just a zip code) in a computer program such as this will provide the most accurate analysis of the local terrain between the transmit antenna and the receive antenna and the television signals that are likely to be received at that location.

Visiting this easy-to-use website (www.antennaweb.org) is a good start to selecting an antenna for DTV reception.

PREAMPS, CABLE, AND SPLITTERS

Q: What types of signal amplifiers are available?

There are three basic types of amplifiers for a viewer to consider. The first type is a built-in antenna amplifier that resides inside the antenna housing itself. It is powered remotely, usually through the coaxial cable itself, from a power supply inside the house through use of a power inserter unit.

The second type is an external mast-mounted amplifier that is typically attached to the outdoor antenna stand that is mounted on the roof. This amplifier is also typically powered through the coaxial cable from a remote power source in the house.

The third type is an external distribution amplifier that typically resides inside the house, and is often used to distribute the antenna signal to multiple television sets. Often these types of amplifiers will have multiple outputs since they contain internal signal splitters, although sometimes they will have only one output which then requires an external signal splitter.

Q: What are the most important parameters of signal amplifiers?

Preamplifiers have several important parameters to consider when purchasing them. The first parameter is *noise figure*, which represents how much extra noise a real amplifier adds to the signal itself. No amplifier is perfect, and all amplifiers add some amount of noise. Noise figure is represented in “dB” (a logarithmic term), and a lower value indicates less added noise, and is therefore better. Typical noise figure values to consider would be between 2 - 5 dB.

The second parameter is *gain*, which represents the amount of signal amplification, and is described also in terms of “dB”. Higher gain is represented by a large dB value. The primary purpose of the amplifier is to overcome subsequent signal loss due to excessively long feedline cable or use of many splitters. It may be tempting to assume that larger gain is always better, but this would not be correct. One should only use as much gain as needed since too much gain may cause the amplifier to go into overload, not only caused by a desired signal that is too large but more likely by the presence of large nearby interference signals. Typical gain values to consider would be between 15 – 25 dB.

The third parameter is **3rd order intercept point (IP3)**, which represents the amount of overload robustness, and is described in terms of “dBm” (a measure of signal level). A large IP3 means a more robust amplifier performance that is harder to overload. Unfortunately, most consumer preamplifiers do not have this important specification listed on the unit or the box that it came in. Therefore, the consumer must depend on other sources of information to determine if a particular amplifier is robust to minimize the occurrence of overload. Typical IP3 values to consider would be between 24 – 30 dBm.

All of the consumer amplifiers under consideration have 75-Ohm input and output impedances, which would then match the typical antenna, cable, and splitter impedance used in the consumer accessories business.

Q: What are the different types of cables that can be used to transport the signal from the antenna to the DTV receiver?

There are two basic types of cable. The first type is 300-Ohm **twin-lead** cable, sometimes called balanced cable. It is generally flat with two obvious wires embedded in it. This type usually has each of these twin leads stripped bare or with spade lugs in order to connect them to the antenna or to a 300-Ohm to 75-Ohm adapter to connect to the DTV set.

The second type (more often used these days, and generally recommended) is 75-Ohm **coaxial** cable. It is a round cable that has an inner conductor and an outer shield conductor that is contained in a plastic sheath. There are a variety of different types of coaxial cables, but a double-shielded type is recommended over a single-shielded type. These cables typically have round threaded male F-connectors placed on each end, typically connecting directly to the antenna and the DTV set. Double-shielded RG-6 or RG-11 cable is recommended.

Q: What are the most important parameters of coaxial cables?

The first parameter is **frequency response**, which represents how the signal attenuation varies with frequency, and is described in terms of MHz. A higher value for the frequency response means it can handle more TV channels. The cables should be capable of handling the entire spectrum of the DTV signals that it will transport. Typically, this means that it should be capable of handling *at least* 800 MHz during the transition and at least 700 MHz after the transition. Typically, cables rated ≥ 1 GHz will suffice.

The second parameter is **loss**, which represents how much signal attenuation will occur in the cable, and is described in terms of dB or dB per foot. As the cable length increases, the signal loss also increases. A lower dB value means lower loss is experienced by the signal as it travels through the cable. Typically, loss values to consider would be between 0.05 – 0.1 dB/foot. Of course, excessive loss in a receive system can cause loss of DTV reception, but can be somewhat mitigated by carefully using a robust amplifier at the beginning of any long cable runs. Remember that cable loss increases with increasing frequency.

The third parameter is the **number of shields**, which represents the effectiveness of its shielding, with more shields providing better rejection of stray interference from impairing the DTV signal. Shields can be made with foil or braid, or both. Sometimes shielding effectiveness (%) is given by the manufacturer, with a larger value being better. Typically, the number of shields to consider would be two or more.

Q: What types of splitters are available to viewers?

The most common type of passive splitter is the 75-Ohm version that has threaded female F-connectors for connection to round coaxial cables. These units typically come in metal cases, with versions for 2-way, 3-way, 4-way, and 8-way splitting. For best performance, unused outputs should be terminated with a 75-Ohm terminator, which is just a male F-connector with a 75-Ohm resistor inside. It is important to note that as the number of outputs increases and the signal is split more ways, the signal level at each output gets smaller and smaller, which can be overcome by placing a distribution amplifier just before the splitter, if necessary. Typically, the number of “splits” should not be any more than is necessary to feed all of the desired receivers, and the splitter should be rated for the entire television frequency band (54 – 700 MHz).

DTV RECEIVERS

Q: What is a coupon eligible converter box (CECB)?

A converter box is an easy-to-install (i.e., self-installed) stand alone electronic device that provides digital-to-analog conversion so that a DTV signal received *off-the-air* with an antenna (either outdoor or indoor) is converted from its digital format to an analog format that is compatible with older analog television sets. The converter box does NOT have to be the same brand as the analog TV set. The CECB will transform all the digital video formats (HDTV, EDTV, and SDTV) to lower resolution standard definition analog television signals. Therefore, HDTV programs will be “watchable” with converter boxes (due to downconversion), but no HDTV video will be available at their output (which cannot be displayed as HDTV on an analog television set anyway). To watch HDTV programs in true high definition, a new HDTV receiver that is capable of displaying the high resolution video would be required. CECB units do **NOT** work with cable or satellite television signals.

The converter box, a small unit about the size of a paperback book, allows an antenna signal to be input to the converter’s antenna port via a traditional 75-Ohm F-connector. It essentially takes the place of the analog tuner in the television set. The converter box also allows an output connection to an analog television set via a coaxial cable (included) that carries a CH 3 or CH 4 (selectable) RF signal from an F-connector on the converter box rear panel. Additionally, color-coded video and audio cables (not necessarily included with the converter) are available to carry composite baseband video and stereo audio signals from the converter’s color-coded RCA jacks to the analog set. These input and output connections are identical to those found on most analog VCR units that have been in use for many years, and which should be familiar to most users. One converter box is needed for *each* analog TV set (or other analog-only device, such as a VCR) that is to receive DTV signals. For specific questions, the local retailer or the manufacturer’s technical support hotline can be referenced.

These units can be found in participating (i.e., certified) retail stores nationwide as well as on-line stores, and they typically cost between \$50 and \$70. However, this amount can be defrayed by using a coupon supplied by the government that is worth \$40. See the following website for more coupon information: www.ntia.doc.gov/dtvcoupon/index.html.

Q: How should a converter box be connected to an analog television (i.e., installed)?

The converter box must be placed *after* the antenna and its cable feedline but just *before* the analog television receiver. This is easily done by removing the round coaxial cable from the analog set’s input and placing it on the converter box’s antenna round F-connector input. Then the coaxial cable that comes with the converter box is connected from the converter’s F-connector TV output to the analog set’s F-connector “antenna” input in the rear. Remember that if flat 300-Ohm twin-lead cable is being used from the antenna instead of the 75-Ohm coaxial cable, then an appropriate 300-Ohm-to-75-Ohm adapter (called a “balun” or a “matching transformer”) must be used since all converter boxes have 75-Ohm F-connector inputs. Some of the converter boxes may come with a “Quick Start Guide” in addition to the paper manual. The NTIA coupon program does NOT provide technical support for converter box installation.

One converter box is needed for *every* over-the-air analog reception device since it basically replaces the analog set’s tuner in that one device. Therefore, if one program is desired to be recorded on an analog VCR and *simultaneously* watch a different program on an analog television set, each unit would be required to attach to a converter box for independent operation.

An example of how to *connect* such a converter box to an analog TV set can be found at the following websites: www.fcc.gov/cgb/consumerfacts/converterbox_vcr.html, www.dtv.gov/publications.html, www.digitaltips.org/video/default.asp or www.zenith.com/dtv/setup.html. Of course, questions can be directed to the retailer where the converter was purchased or to the manufacturer of the converter box.

Q: How does one know whether to select CH 3 or CH 4 as the RF output of the converter box?

The selection of an RF output channel (if used to connect the converter box instead of the composite video and the left and right audio outputs) is the same as for a VCR. If there is a local off-air signal on CH 3, then the converter box RF output should be selected to use CH 4. On the other hand, if there is a local off-air signal on CH 4, then the converter box RF output should be selected to use CH 3. If neither CH 3 nor CH 4 is used locally for over the air, then either can be selected. Information on how to select the converter box RF output channel can be found in the manufacturer's manual.

Q: Can a legacy analog VCR be used with the converter box?

Yes, but after February 17, 2009, the older analog-only VCR itself can not be used to tune in the DTV signals. Therefore, it must be connected to the converter box RF *output*, and the VCR must be programmed to tune to either CH 3 or CH 4 (whatever the converter box output is set up for). The problem is that the converter box must be manually tuned to the desired television channel to be recorded *prior* to each recording session since the VCR can not control the converter box tuner.

Ultimately, a new VCR (perhaps with an included recordable DVD) with a built-in digital ATSC tuner can be purchased that will allow the VCR to tune any DTV channel (as determined by its user programming), decode the video and sound, and then record it accordingly.

Q: Can a DTV program be watched simultaneously while recording it with an analog VCR?

Yes, this can be done as long as there is a converter box in front of the VCR, and the *same* program that is being recorded is being watched. However, to watch one program and record a different program requires two converter boxes.

It should be noted that new VCR devices (usually in combination with DVD players/recorders) are now on the market that have built-in digital tuners so that they operate with DTV signals similarly to the old analog VCR units (i.e., the VCR can control its *internal* digital tuner).

Q: Can a viewer using a converter box still view closed captioning?

Yes, a viewer can still view closed captioning since all converter boxes are *required* by law to provide basic closed captioning for display on analog sets. This means that if the advanced form of closed captioning is sent by the station, the converter box will convert it to basic closed captioning and send it to the analog television set so that it can be decoded and displayed.

However, the closed captioning *features* may vary between CECB converter boxes. Some boxes can actually decode the closed captioning themselves and then insert the text into the video. This gives the viewer the flexibility to use either their analog television's basic closed captioning decoder or they can use the converter's closed captioning decoder. This may make a difference to the viewer if the station is transmitting the advanced closed captioning and the converter can decode and display the advanced form of closed captioning, which includes fancier fonts and colors.

The FCC has produced a guide that lists selected features, including closed captioning, for a number of converter boxes, and can be found at: www.fcc.gov/cgb/consumerfacts/converterboxfeatures.html.

Q: How can one tell if a converter box has analog pass-through capabilities for use with low-power television (LPTV) stations and translators after February 17, 2009?

Analog pass-through is the ability of a digital-to-analog converter box to allow analog television signals (such as those from LPTV stations or translators) pass through them directly to the analog television set. The government permits manufacturers, not retailers, to determine the converter box packaging. Some converter boxes with analog pass-through *may* not be clearly marked on the carton, and therefore should be thoroughly checked to determine if this feature is present in the converter box being purchased. Retailers may be able to identify the presence of analog pass-through on a particular brand or model of converter box, and manufacturer websites and phone numbers may also provide the desired information. Also, the NTIA lists all the converter boxes to date that have been certified with analog pass-through at: www.ntiadtv.gov/cecb_list.cfm.

Q: What various features and accessories can be found on the different converter boxes?

Various features and accessories are *mandated* on the certified converter boxes, such as a remote control with batteries, owners manual, front-panel power status LED, closed captioning, parental control (i.e., V-Chip), emergency alert system information (EAS), a signal quality indicator, complete channel scan, and 2-Watt “sleep” state energy standards (e.g., CEA-2013-A).

However, certain other features are allowed (i.e., *optional*) but *not* mandated, such as a smart antenna interface (CEA 909A) connector, a 300-Ohm-to-75-Ohm matching transformer (“balun”), a built-in analog pass-through feature, an external bypass switch to simulate analog pass-through feature, an S-Video output connector for higher quality analog video output, either monaural or BTSC stereo outputs on the CH 3 or CH 4 RF output, automatic software update capability, *extended* television program information, a programmable *universal* remote control, dedicated remote control keys for closed captioning and descriptive video functions, battery-powered converter box operation, additional cables (e.g., video and audio cables or an S-video cable), *extended* on-screen RF signal quality information, add-on scans, direct RF channel tuning, and adhering to additional EPA Energy Star program standards or state regulatory energy program standards.

There are three important *optional* features mentioned above that a viewer should seriously consider when purchasing a converter boxes. These two options particularly relate to DTV reception issues.

The *first* very important optional feature is ***add-on scanning***. Add-on scanning, unlike complete channel scanning that deletes all the channel information from the converter box’s memory, just *adds* new channels that are found and adds their information into the converter box’s memory. This is a handy option when the outdoor or indoor antenna must be manually repositioned to get DTV reception of other groups of channels.

The *second* optional feature that is also very important is ***direct RF tuning***. If a viewer knows the *actual* RF channel of a digital station, and that digital station is very difficult to receive and/or manually adjust the antenna for good reception, then the viewer can enter the actual digital RF channel into the converter box, and it will directly tune to that channel while the viewer adjusts the antenna to get reception. Upon successful reception of this particular DTV station, the converter box will then store all the vital station data just like the other channels that were found during an automatic channel scan.

A *third* option that is not important to all viewers, but is very important for viewers who live in areas that receive low-power television (LPTV) or translator signals is analog pass-through. This feature allows the viewer to *conveniently* still watch analog signals from LPTV stations and translators by simply turning off the converter box. In the off state, the converter box bypasses the digital tuner and

passes any signals at the antenna input, including analog LPTV signals, through the box unaffected so that the analog television set can receive them as it always has in the past.

More information for *specific* converter boxes can be found at:

www.consumerreports.org/cro/electronics-computers/televisions/digital-tv-converter/overview/dtv-converter-box-guide.htm

en.wikipedia.org/wiki/Comparison_of_CECB_units

www.fcc.gov/cgb/consumerfacts/converterboxfeatures.html.

Q: How can one tell if their *present* television set has DTV capability or not?

To determine whether your television equipment purchased prior to May 25, 2007 is a DTV set, many DTV units and digital television equipment will have labels or markings on them, or statements in the informational materials that came with them, to indicate that they contain digital tuners. These labels or markings may contain the words “Integrated Digital Tuner” or “Digital Tuner Built-In.” “Receiver” may be substituted for “Tuner,” and “DTV,” “ATSC,” or “HDTV” (high definition television) may be substituted for “Digital.” If there are any input connections labeled “digital input” or “ATSC” on the television set, the unit is a DTV. If your television equipment contains any of these labels or markings, you should be able to view digital over-the-air programming without the need for a digital-to-analog converter box. You should also check the owner’s *manual* or any other materials that came with your television equipment in order to determine whether it contains a digital tuner.

Every set made *before* 1998 was a traditional “analog” television. These television sets might be labeled as “analog” or “NTSC” or not labeled at all, and therefore should indicate to the viewer that they are analog sets.

Big-screen, projection television sets (42” and larger) sold between 1998 and 2004 have a *chance* of containing a built-in digital tuner inside, although only a small percentage of these sets had digital tuners (i.e., most were DTV or HDTV *monitors*, sometimes referred to as being “HDTV ready” or “Digital Ready”, and were only display devices that required an external set-top box digital tuner to receive digital signals off the air).

However, large-screen sets purchased in 2004 and after have a much greater chance of having a built-in digital tuner as these sets began to sell in large numbers, although there is still no guarantee since some of these more recently-manufactured sets were *monitors* (i.e., without digital tuners).

By federal law, as of **March 1, 2007**, all television receivers (i.e., all television reception devices, including TVs, VCRs, DVDs, DVRs, etc.) *shipped* in interstate commerce or *imported* into the United States must contain a digital tuner if there is an analog tuner present. However, retailers were allowed to continue to sell analog-only devices from existing inventory. Effective **May 25, 2007**, the FCC required sellers of television receiving equipment that does not include a digital tuner to prominently display on or near the analog-only device (i.e., at the point of sale) a Consumer Alert label indicating that such devices include only an analog tuner. Therefore, after **May 25, 2007**, all television equipment being sold *should* contain a digital tuner, or it should be clearly identified at the point-of-sale as not having one. A consumer should be sure to look for this information if purchasing a new TV in order to not be surprised and disappointed later when connecting the new television set to an antenna only to find out that it does not have a digital tuner inside.

One can always contact the manufacturer directly as well as visit the manufacturer's and/or retailer's web site to determine if the specific model under consideration is a DTV set.

Q: When purchasing a new television set, how can a consumer be certain that it is a digital television set?

By federal law, as of **March 1, 2007**, all television receivers (i.e., all television reception devices, including TVs, VCRs, DVDs, DVRs, etc.) *shipped* in interstate commerce or *imported* into the United States must contain a digital tuner. Retailers may continue to sell analog-only devices from existing inventory until they run out of stock. However, effective **May 25, 2007**, the Commission required sellers of television receiving equipment that does not include a digital tuner to prominently display on or near the analog-only device (i.e., at the point of sale) a Consumer Alert label indicating that such devices include only an analog tuner, and therefore will require a digital-to-analog converter box to receive over-the-air broadcast television after the analog turn-off date. Retailers must inform consumers by prominently displaying the following text if they are selling TV equipment with only an analog tuner:

This television receiver has only an analog broadcast tuner and will require a converter box after February 17, 2009, to receive over-the-air broadcasts with an antenna because of the Nation's transition to digital broadcasting. Analog-only TVs should continue to work as before with cable and satellite TV services, gaming consoles, VCRs, DVD players, and similar products. For more information, call the Federal Communications Commission at 1-888-225-5322 (TTY: 1-888-835-5322) or visit the Commission's digital television website at: www.dtv.gov.

Q: If a viewer buys a new digital television set, is it necessary to buy a more expensive HDTV set?

No, it is not necessary to buy an HDTV set. An SDTV digital set will tune in and decode all the different DTV video formats, downconverting each format to a lower SDTV resolution for display. This would be very useful and practical for small screen DTV where HDTV cannot be appreciated or even noticed due to the small size of the screen.

However, for larger screen sizes (30" and larger), where HDTV can be appreciated, most (if not all) television manufacturers provide HDTV capability. The prices of these larger-screen HDTV sets have come down dramatically in the last couple of years, and should be considered by serious large-screen DTV shoppers.

Q: What are the various output formats that can be viewed on a 4:3 aspect ratio analog television set, and how will they look?

When the aspect ratio of the transmitted television program does not match the aspect ratio of the television set's screen, black bars may appear on top and bottom and/or the left and right sides of the picture. On a 4:3 legacy analog television set, a matching 4:3 aspect ratio digital signal will obviously fill the entire screen as expected, without any black bars and no missing video information.

A 16:9 aspect ratio digital signal can be viewed on a 4:3 analog set either entirely horizontally that leaves black bars at the top and bottom (letter box) or the center portion of the video can be displayed on the analog television (chopping off the sides of the video but filling the entire screen). However, if a 16:9 picture is transmitted from the television station's studio with black bars already on the sides (e.g., if SDTV video originated in 4:3 but was upconverted to 1080i or 720p with black side panels before transmission), then the legacy analog set could treat it as a 16:9 aspect ratio video signal and thus display it with black bars on top and bottom and both sides (postage stamp). Or it could take the center portion of the signal and stretch it (called zoom) to fill the entire screen without losing any program material.

Some of these display issues are being taken care of automatically in new DTV sets and in some (but not all) of the converter boxes by using automatic format descriptors (AFD) that allow the TV station to tell the DTV receiver the best way to display the video. Ultimately, this will be the way that all DTV stations will operate in the future.

Since these display options can vary from one manufacturer to the next, the manual should be referenced.

Q: What are the various converter output formats that can be viewed on a 16:9 aspect ratio digital television set, and how will they look?

When the aspect ratio of the transmitted television program does not match the aspect ratio of the television set's screen, black bars may appear on top and bottom and/or the left and right sides of the picture. On a 16:9 digital television set, a 4:3 aspect ratio digital signal will have bars on the left and right sides (pillar box), although it may be stretched (called zoom) horizontally to fill the entire screen (and distorting the image).

A 16:9 aspect ratio digital signal will fill the entire screen without distorting the image, as expected. However, if a 16:9 picture is transmitted from the television station's studio with black bars on the sides (if SDTV video originated with a 4:3 aspect ratio but was upconverted to 1080i or 720p which has a 16:9 aspect ratio), it will keep the black bars on the sides (pillar box). Or it could be stretched to fill the whole screen (and thus look distorted). If a 4:3 aspect ratio signal is upconverted to 1080i or 720p and *transmitted* as letterboxed for a more modern look, then the displayed signal would have black bars on all sides (postage stamp).

Some of these display issues are being taken care of automatically in new DTV sets and in some (but not all) of the converter boxes by using automatic format descriptors (AFD) that allow the TV station to tell the DTV receiver the best way to display the video. Ultimately, this will be the way that all DTV stations will operate. However, since these display options can vary from one manufacturer to the next, the manual should be referenced.

Q: Will a new DTV set be able to tune and decode the analog broadcast signals?

Yes, they will. All new DTV sets are "backwards compatible" in that they have both analog and digital tuners capable of providing analog and digital programs during the transition (prior to February 17, 2009). After the cessation of full-power analog broadcast signals, the DTV sets will continue to decode analog LPTV and translator stations (that are not required to cease analog broadcasts until some yet undetermined later date) and the post-transition DTV stations. However, the DTV sets (and converter boxes) should be rescanned in order to find any DTV stations that changed actual RF channels on or near February 17, 2009.

Q: Do some DTV sets have built-in low-noise amplifier (LNA) that can be manually activated or deactivated by the user?

Yes, some new DTV sets have this feature which provides for better sensitivity when needed. However, a viewer must be careful to deactivate this feature if there is a chance that strong interfering signals might be present that can overload this amplifier.

Q: Will an analog VCR, DVD, camcorder, and video game work with these new SDTV or HDTV sets?

These units are “backwards compatible”, which means that they will work with both the legacy analog signals and the new digital signals. Therefore, older analog devices will work with the newer DTV sets, but will obviously be limited in picture quality to that used in the legacy device (typically 480i video format with a 4:3 aspect ratio from most analog devices and up to 480p video format with a 16:9 aspect ratio from *some* newer DVD units).

DTV RECEPTION TECHNIQUES

Q: Was there ever an expectation of 100% success rate for all terrestrial DTV reception?

No, there was not. Terrestrial DTV reception, just like traditional terrestrial analog TV reception, is a *statistical* process since propagation effects are described statistically. There will be a percentage of people in any given television market that will *not* have consistent signal *levels* and signal *quality* for acceptable DTV reception.

The FCC assumed planning factors for broadcasters and viewers that would provide acceptable signal levels at 50% of the locations 90% of the time within a desired service area. These percentages can be increased if viewers install receive system equipment that has *better* specifications than assumed in the typical planning factors (e.g., larger gain outdoor antenna raised higher than 30' above the ground, with an *optional* robust mast-mounted low-noise preamplifier and lower loss coaxial cable).

Q: Is there a risk if a viewer waits until February 17, 2009 to try over-the-air DTV reception?

Yes, there definitely is a risk. All forms of over-the-air propagation have risk due to variable propagation conditions. Some sites have little risk and reliable reception is achieved easily and quickly. Other sites have lots of risk, and reliable reception is achieved only after serious thought and some trial-and-error experimentation. The number of variables that can affect reliable DTV reception is significant for outdoor reception and even more so for indoor reception. If this experimentation is done *prior* to February 17, 2009, this can be performed with little time pressure and no immediate loss of television service since the full-power analog stations will still be on the air transmitting their programming.

However, waiting until after February 17, 2009 to experiment (referred to as “predicted procrastination” by those in the broadcast industry) can risk loss of television service while some of the individual solutions are being sought to achieve reliable DTV service (including waiting for NTIA coupons to arrive in the mail or converter box shipments to arrive at retail stores). While almost everyone knows that the end of the full-power transition is coming with the turn-off of full-power analog signals on February 17, 2009, not everyone is sure what to do about it.

Q: What are the different types of DTV reception techniques?

The broadcast industry defines five (5) basic types of reception that are possible with DTV devices today and in the future. They are:

- 1) **Outdoor:** This reception type utilizes an *external* outdoor antenna (VHF and/or UHF), typically mounted on the roof of a building (or in an attic, which is considered quasi-outdoor) that is either adjusted once for best reception upon installation or is adjusted remotely by the viewer with an electric rotor that mechanically rotates the antenna.
- 2) **Indoor:** This reception type utilizes an *external* indoor antenna (VHF and/or UHF) inside a building that is either adjusted for best reception manually or remotely by the viewer.
- 3) **Portable:** This reception type utilizes a *built-in* antenna (VHF and/or UHF) that is *not* adjusted, but must pick up the signal inside a building, if possible, regardless of the physical location or position of the DTV receiver.
- 4) **Handheld:** This reception type utilizes a small *built-in* antenna (typically UHF) that essentially is not adjusted, but must pick up the signal indoors or outdoors while moving ≤ 3

mph (e.g., walking), if possible, regardless of the physical location or position of the DTV receiver.

- 5) **Mobile:** This reception type utilizes a small *built-in* antenna (typically UHF) that essentially is not adjusted, but must pick up the signal outdoors while moving ≥ 3 mph (e.g., in a car, bus, or train), if possible, regardless of the position of the DTV receiver.

Q: Is there a fundamental difference in the reception of analog signals and digital signals?

While both types of signals propagate through the air at the speed of light using electromagnetic waves, decreasing in amplitude with increasing distance from the transmitter (inverse square law), and reflecting off various surfaces (e.g., buildings, bridges, water towers, mountains, etc), the resultant *decoding* of these analog and digital signals is different.

Analog signals will produce a picture that typically degrades gracefully going from a clean picture to a noisier picture to an awful picture as the signal gets weaker or more distorted. Digital signals are different in that they will produce a clean detailed picture even as the signal gets weaker or more distorted until it reaches some “magic” threshold (e.g., 15 dB SNR) where it becomes essentially unusable. This is called the “*digital cliff effect*”, and is characterized by a “mostly there or not there” picture and sound condition. Therefore, it is important to make sure that the reception of DTV signals can be experienced well above the digital cliff threshold to allow for the always possible signal level variation (e.g., signal fading or “breathing”) that occurs with all over-the-air transmission systems.

Q: What do DTV transmission errors look and sound like to the viewer?

DTV is transmitted from the station’s transmitter to the viewer’s receiver in data packets. Some data packets are for video, some are for audio, and some are for reference data. Despite the ATSC system’s robust error correction capability, these data packets are sometimes received in error under certain severe propagation conditions (e.g., weak signals, severe multipath, significant interference, etc.).

DTV transmission errors cause video and audio distortion that does not look or sound like what viewers have been used to seeing or hearing in the traditional analog television system. Transmission errors show up in the video as “blockiness” (in the mild case) or video freeze frames (in the severe case). If the errors strike the audio data packets, the sound will mute momentarily, the length depending on the number and duration of the data errors. While occasional errors do not destroy the DTV reception experience since many viewers can ignore them, heavy errors will render the DTV signal unusable.

Q: How is successful reception defined for analog and digital?

Successful *analog* reception is more difficult to define since the analog signal, for the most part, degrades gracefully with worsening signal conditions (e.g., weaker signal strength, increasing impulse noise, increasing multipath, and increasing interference from other television signals). Picture degradation will vary directly with the intensity of the impairments since the analog signal is viewed on an analog television (i.e., it acts as a “window to the RF world”). Therefore, picture degradation must be judged *subjectively* by viewers. Analog picture quality is typically rated on a *subjective* 5-point impairment scale as such: **Rating 5** is an imperceptible impairment; **Rating 4** is a perceptible impairment, but not annoying; **Rating 3** is a slightly annoying impairment; **Rating 2** is an annoying impairment; and **Rating 1** is a very annoying impairment. For purposes of planning factors, the FCC defines acceptable analog pictures Rating 3 and higher. This is highly subjective in that what is only slightly annoying to one person is annoying to another. That is, “beauty is in the eye of the beholder.”

A problem may currently exist in terms of viewers' perception of what is considered an acceptable analog picture that should be replicated by a DTV signal. While the FCC defines a slightly annoying rating 3 picture as the requirement for replication with a digital signal, it has become clear that many viewers will consistently watch much worse (i.e., more degraded) pictures, especially if the audio is relatively unimpaired. Therefore, there is a perception problem between the digital system's original performance intent, and what is expected by the viewing public today. This can be dealt with by managing expectations of the viewing public in terms of what they should expect to experience with DTV reception and what they need to do to improve their chances of successful reception.

Successful *digital* television reception is a little easier to define because of the sharp transition in the presence of impairments from error-free perfect picture and sound to an all-error frozen picture and muted sound. This sharp transition is called the "**digital cliff effect**". However, contrary to public opinion, while a DTV signal is *essentially* either there or not there, a DTV signal can have an impairment rating somewhere *between* perfect (impairment rating 5) and useless (impairment rating 1). This can occur when a DTV signal is mostly decoded error-free, but takes errors occasionally (i.e., sporadically,) whether it is a couple of errors in an hour or a couple of errors in a minute. Typically, two short (1-second) visible errors, in a minute is generally thought to be the limit of acceptable DTV reception. More than this and most viewers may deem DTV reception unacceptable. In reality, while *occasional* burst errors that cause video pixelization or freeze frames is disturbing, the intermittent muting of the audio is the most annoying.

Q: What assumptions did the FCC make in allocating an extra channel to each eligible broadcaster, and how do they affect whether a viewer can successfully receive digital signals?

The overarching goal for the FCC was analog service *replication* (i.e., duplication) with the DTV signal. That means whatever percentage of households had an acceptable (i.e., impairment rating 3 or better) analog picture would also get an acceptable digital picture *on that same RF channel*. However, there was never any stated expectation by the FCC or broadcasters that 100% of the households would have DTV reception, just as that is true for analog television reception. It was expected that replication would occur statistically across a station's service area. Likewise, it was also expected that for every household that had acceptable analog reception but unacceptable DTV reception, there would be another household with unacceptable analog reception and acceptable DTV reception.

The original selection of an impairment Rating 3 as the limit of acceptable analog picture quality for the purposes of service replication is slightly controversial in that many of today's viewers appear to judge pictures as acceptable that are worse than a traditional Rating 3 (e.g., Rating 2 or even Rating 1.5). If viewers judge as acceptable analog pictures that are worse than what the FCC assumed as acceptable, replicating analog service with digital signals may prove to be more difficult than anticipated. Adding to this difficulty is the fact that some final post-transition actual DTV RF channels may not be on the same channel as the pre-transition analog channel, and perhaps not even in the same television frequency band. Since there are different propagation characteristics among the three television bands (low-VHF, high-VHF, and UHF), this may also make replication with the analog service that much tougher.

The FCC assumed a number of transmission parameters at both the station's transmitter location and the viewer's receiver location. For the broadcaster, the location of their transmit tower, the antenna height above the average terrain, the directivity of the transmit antenna pattern, and the signal's effective radiated power (ERP) are all part of the channel allocation process.

The FCC also assumed a *typical* set of performance parameters for the viewer's receive system. Of course, there is no one set of receive site parameters used by all the people in the United States, so a single set of "reasonable" *assumptions* were made for the receive site regarding antenna gain, antenna height above ground level, downlead cable loss, "magic" threshold of error-free operation (e.g., 15 dB SNR), and DTV receiver sensitivity (-83 dBm in 6 MHz).

The FCC also assumed that the viewer would make a "*reasonable*" effort to receive the television signals (both analog and digital), such as using an outdoor antenna whenever possible, orienting the antenna in an optimum direction towards the various transmitter towers, using a higher gain antenna if necessary, raising the antenna farther off the ground if necessary, inserting a mast-mounted preamplifier if necessary, and using the most sensitive DTV receivers available. For these reasons, careful selection of these various receive system components may be necessary for a viewer to achieve successful DTV reception, and experiments should be performed *before* February 17, 2009 while analog signals are still available. For those unable or unwilling to study these concepts, help can come from various sources such as broadcasters, consumer manufacturers, retailers, and the government using a variety of techniques (written brochures, websites, live presentations (seminars), and TV programs).

Q: Are there FCC planning factors for *both* indoor and outdoor antenna reception?

No, there are not. Due to the very difficult problem of accurately determining the propagation parameters that affect indoor reception, the FCC did not create indoor planning factors or assume that widespread indoor antenna use would always be possible for *either* analog or digital television. The assumption was that if indoor reception in a given location and a given building structure would be acceptable (impairment rating 3 or better) for reception of analog signals than it *might* be possible for reception of digital signals. However, the final determination would not be known until it was tried. If indoor DTV reception was not reliable enough, then an outdoor or attic antenna would be required by the viewer.

Q: What are the basic *guidelines* for TV signal reception?

- (1) *Outdoor antennas are generally better.* This is because they typically have a better "view" of the transmit antenna (if properly placed on the roof), with a greater chance of stronger signals and less chance of local obstructions (including people walking near or around the antenna) or intervening terrain obstructions. This is important since reliable TV propagation is *essentially* line of sight. Outdoor antennas also have the benefits of avoiding signal loss that typically comes with lower antenna heights and building-induced attenuation, as well as minimizing any impulse noise interference or building-induced signal reflections that commonly occur indoors.
- (2) *Higher antenna locations are generally better.* A receive antenna that is raised to a higher location above the ground has not only a better "view" of the transmit antenna (i.e., better chance for line-of-sight propagation) but it also reduces electrical interferences from within the home and signal reflections from nearby structures. Regardless of the exact height of an outdoor antenna above ground level, it should be at least 4' above the structure (preferably 10' if placed above a metal roof) to which it is mounted and certainly above the roof line for best TV reception.
- (3) *Closer locations to the transmitter are generally better.* Sometimes it is not possible to place an antenna on the roof. In this case, place it on the side of the building that is closest to (and facing) the desired transmit antennas for the best chance of line-of-sight reception.

- (4) *Bigger antennas are generally better.* A larger antenna (e.g., more antenna elements) has more “gain” and thus provides more signal received level. Size also relates to the television band in which the desired signal is transmitted. For instance, television signals transmitted in the low-VHF band (i.e., CH 2 – CH 6) have longer propagation wavelengths than those in UHF and therefore require longer (i.e., wider) antenna elements to efficiently receive the signal, which requires the size of these antennas to be larger. Also, larger antennas that have more gain achieve this by being more directional, which may reduce some of the signal reflections from the sides and back that cause multipath (referred to as “ghosting” in analog TV sets and echoes in DTV sets).

Q: Will an antenna placed in the attic still receive television signals?

It is possible to still receive television signals with an attic antenna, but generally antennas will not work as optimally in the attic as outdoors (e.g., on the roof). This is because signal levels may be reduced by 50% or more from those outside on the roof. Also, if there is aluminum siding, foil-backed insulation, or a metal roof, RF signals will be severely blocked and possibly render the signal too weak for acceptable analog or digital reception. Since an attic antenna is located lower above ground level than an outdoor antenna and resides within the four walls and the roof of the house, the chance for electrical interference increases. Placement within the attic also increases the chance for signal reflections that cause “ghosting.”

Of course, the advantages of an attic antenna over an indoor antenna are that it is higher above the ground and people generally will not be walking around and in front of the antenna which can affect its performance.

Q: Is a special antenna needed to receive free, over-the-air DTV signals?

No, there is *not* a need for any special antenna since *both* analog and digital television signals use the same 6 MHz channels in the same television bands (low-VHF, high-VHF, and UHF), and therefore require the same type of signal reception equipment. In general, if a viewer’s existing receive equipment (e.g., an outdoor directional antenna) works well with analog signals to provide good quality pictures, it *probably* will work well with digital signals in the *same* frequency band (assuming the digital broadcaster is transmitting at full allocated power).

However, depending on the circumstances in a given market (i.e., what actual RF channels are being used for analog and digital *before* February 17, 2009 and what actual channels will be used *after* February 17, 2009), there may still be a reason for a viewer to change from one type of television receive antenna to another. For instance, if only VHF (i.e., CH 2-13) analog signals are being received on the viewer’s outdoor VHF-only antenna, and the digital RF channels are all on UHF channels, they are highly unlikely to be received by the DTV set. To resolve this issue, an outdoor all-band (i.e., VHF and UHF) antenna would be required to receive both analog and digital signals during the transition period.

Q: What is the first thing that should be done after the antenna is installed and connected to the DTV receiver?

Aim the antenna generally towards the DTV transmitters serving the viewer’s area. Turn on the DTV set, and perform a complete channel *scan*. This scan will tune every possible channel in the VHF and UHF television bands looking for decodable DTV signals. When it finds one, it notes the *actual* RF channel, reads the digital data that contains information about its *virtual* channel (typically the analog

channel number, which is defined as the *major* channel number, how many sub-channels exist in each RF channel, and some other important data). This information goes into various look-up tables in the DTV set's memory, and allows a viewer to then use the virtual channel numbering scheme that they are used to using to tune in their favorite television stations.

At this point, the viewer does not need to know the actual RF channel number for each DTV signal. However, knowing the actual DTV channel number prior to this may help the viewer properly select the best antenna for DTV reception.

Q: Why should a viewer re-scan the DTV receiver immediately following February 17, 2009?

At 11:59 pm on February 17, 2009 (or before), any broadcasters still broadcasting in the 700 MHz spectrum (i.e., CH 52 – CH 69) are required by law to vacate these frequencies to make room for public safety (*approximately* CH 63, CH 64, CH 68, and CH 69) and new commercial broadband services. Television stations are required to use only the new “core spectrum”, which is defined as CH 2 to CH 51, inclusive.

They must, therefore, move their DTV signals down into the core television spectrum (CH 2 – CH 51). Likewise, *some* broadcast stations will choose to move their DTV signals back to their original (but now vacated) analog channel assignment. Other broadcast stations will move their DTV signals to different RF channels other than their existing (i.e., pre-February 17, 2009) DTV and analog RF channel assignments. Consequently, these stations will suddenly have different *actual* DTV RF channel assignments that every DTV receiver must search for and identify. And yet others will remain on their existing pre-transition DTV channels after February 17, 2009.

Therefore, a channel re-scan is necessary to find these new channels, and record them in the receiver's channel table memory. However, the viewer will still use the virtual channels for channel selection that are being employed today. That is, CH 5.1 or CH 5.2 will still be referenced in this manner, with the DTV receiver using its knowledge from the scan to make tuning easier for the viewer. However, CH 5-0 (the major full-power *analog* channel) will not be present since full-power analog signals will have been shut-off by the end of the day on February 17, 2009.

Q: How does a signal strength or signal quality meter help in adjusting an antenna or in determining if the signal quality is acceptable at the viewer's location?

Unlike an analog television set, a DTV receiver does not display on its screen any impairments in the received signal (i.e., essentially the picture is either good or bad). Therefore, a viewer cannot look at the picture to determine the optimum antenna setting. However, by activating the built-in signal quality meter (either via a button on the remote control or via the on-screen menu), the viewer can adjust the antenna for a given channel to maximize the received signal's quality. Of course, to perform this antenna optimization, the desired channel had to be previously stored in the channel scan's virtual channel memory or the viewer had to directly enter the DTV stations actual RF channel number (assuming the DTV receiver has the ability to directly tune in a station using actual channel numbers instead of virtual channel numbers).

Q: When should an *amplified* antenna be used, and what techniques should be employed when using them?

Under certain circumstances, an amplified *outdoor* antenna can improve sensitivity of an analog or digital television's tuner by increasing the signal level before it is applied to the download coaxial cable

that connects to the receiver. It may be called for if a viewer is on the fringe of a DTV station's service area, or is in a location where signals are weak for a variety of reasons, including (but not limited to) some form of terrain or man-made blockage that limits line-of-sight to the transmit antenna.

An amplified *indoor* antenna may be called for if a viewer is at an indoor reception location with weak signals that may be caused by being on a lower floor of the building or on the opposite side of the building facing away from the desired transmitter tower thus causing lots of building attenuation. The amplifier often will have a noise figure that is lower than that of the DTV tuner, and thus provide some extra margin for DTV reception.

The internal or external antenna amplifier should be low noise (noise figure < 4 dB) with moderate gain (18 – 24 dB), and robust against overload (IP3 > 25 dBm).

Q: How should a viewer set up an antenna to receive multiple DTV signals when there are at least two very distinct clusters of transmitter locations that cause the received DTV signals to emanate from different directions?

While many cities do not have all their TV transmitter antennas exactly co-located (the ideal situation), many of them are situated *reasonably* close to one another so that viewers can just aim their receive antennas in the general direction of the transmitter sites and get acceptable signals. Most consumer receive antennas have a beamwidth of about ± 30 degrees or more, while still maintaining a reasonable front-to-back ratio to reject interfering signals from the back and sides.

However, there are situations where two or more transmitter sites are separated from each other by a large distance causing many viewers in the general television service area to experience large antenna pointing angle *differences*. Under these circumstances, special techniques are in order.

There are basically *five* methods to consider: (1) a “multi-directional” antenna, (2) a “bi-directional” antenna, (3) combined multiple directional antennas, (4) an “omni-directional” antenna, and (5) an electromechanical rotor to be used with a directional antenna.

(1) The use of a **multi-directional** antenna allows reception over a much wider area than a high-gain directional antenna since it has a large beamwidth (± 45 degrees for 5 dB bandwidth), yet it still provides some good attenuation to the sides and rear of the main beam. If the various DTV transmitter sites are within a 90-degree pointing angle from the viewer's location, this type of antenna *may* solve the problem.

(2) The use of a **bi-directional** antenna allows DTV reception from both front and back if the various DTV transmitters are situated both in front and behind the viewer's location. Attenuation is still provided to the sides of the antenna.

(3) The use of **two or more separately-aimed antennas** that are properly combined in a combiner unit is another option. Each antenna is optimally aimed toward a distinct set of transmitter towers for best DTV reception. This may be a problem for analog television reception since each antenna may pick up signal reflections from the desired stations towards which the antenna is not aimed and thus cause “ghosting” (i.e., multiple images caused by the echoes). However, this method *may* work in many instances for DTV reception since DTV receivers have the capability of echo cancellation of strong echoes. This would allow the use of highly directional, high-gain antennas with all of their benefits as well as quick channel surfing (no slow mechanical rotor to move for optimum antenna aiming). Of course, multiple antennas must be mounted on the roof along with a combiner unit, and any strong echoes caused by using two

antennas must not be too severe. Also, if the two directional antennas are receiving signals in the same TV band, they should be separated by a minimum distance to avoid interaction with one another.

(4) The use of an **omni-directional** antenna solves the problem of a slow mechanical rotor to re-aim the antenna or multiple antennas to mount on the roof with a combiner. However, these pseudo-omni-directional antennas are typically low gain units (although some come with an amplifier in them which helps overcome cable loss), and they do *not* reduce signal reflections from the sides or back. Also, these pseudo-omni-directional antennas do *not* have exact circular antenna patterns, but they may have nulls in some directions for some channel frequencies, so they may even have to be “aimed” by tweaking their positioning so that all the desired DTV channels are received reliably.

(5) The use of a roof-mounted electromechanical **rotor** has been around for quite some time, with units still being sold (there is even a small version available included with VHF and UHF *indoor* antennas). The outdoor rotor unit is placed up on the roof with its control wires, and rotates the pole to which a television antenna is mounted. The user, via a remote control unit, controls the position of the rotor (and hence the antenna) to point the antenna in the optimum direction for best DTV reception for a given DTV channel. Fancier units will remember the position of the rotor for the previously stored direction for each desired channel. This has the advantage of using a highly directional, high-gain antenna with all of its benefits for receiving signals in a variety of directions. Of course, channel surfing will be slowed down if the antenna has to be slowly turned mechanically to different positions for most of the channels.

Q: What can be done if I need to feed more than one DTV set from my outdoor antenna?

A passive signal splitter can be used to feed multiple DTV sets (e.g., 2, 4, or 8), if desired. However, the signal level is decreased proportionally by the number of splits (signal attenuation is approximately $\frac{1}{2}$ for a two-way splitter, $\frac{1}{4}$ for a 4-way splitter, etc.). If the received signal is weak to start with, the signals transported to the various DTV sets will be even weaker and may fall below the “magic” threshold of visible errors (TOV), thus producing no DTV picture or sound. It is best to use a splitter that has no more splits than are needed, minimizing the reduction in signal level. If the number of signal “splits” is required to be large and/or the remaining cable lengths need to be long, a distribution amplifier might be needed just *before* the splitter.

Q: What must be done to *increase* the chances for reliable outdoor DTV reception?

A good receive system must be employed in the viewer’s residence. This means using a good antenna (preferably outdoors, on the rooftop and aimed properly), minimal-length low-loss feedline cable, and a robust modern DTV receiver (made within the last few years).

If necessary, a *mast-mounted* robust amplifier might be needed at the antenna output in a weak signal situation or perhaps an attenuator might be needed at the DTV receiver’s input in an overload case, as well as signal splitters if more than one DTV set is to be connected to the receive antenna. If severe multipath is present, then a medium or large antenna with very directional characteristics may mitigate the problem if the echoes are coming from the sides or rear of the antenna.

Q: What techniques might be used to increase the chances of reliable indoor reception?

The higher the receive antenna is off the ground, the better chance for reliable reception. An indoor DTV reception on *upper* floors of a building is often much better than on the first floor or in basements. Sometimes using an amplified indoor antenna (antenna with built-in amplifier) will help if the signals are weak. However, if there are lots of strong signals in the area (i.e., potential interferers), an amplifier can actually make things worse if it is overloaded by the strong interfering signals. In the cases of overload, an attenuator (sometimes called a “pad”) placed at the DTV receiver input will improve DTV reception.

Sometimes using a directional antenna located near a window facing the transmitters and pointing towards the transmitter towers (rather than a bi-directional antenna in the middle of the room like rabbit ears or loop antennas) will help minimize the effects of people moving about the room. If a large picture window or sliding door has metal blinds hanging over it, open the blinds when watching television, preferably by raising them up all the way.

Q: At what distance should one expect to be able to receive reliable indoor DTV reception?

This can not be predicted accurately because of the large variations in a number of variables involved. For instance, a very general rule of thumb is that decent indoor reception *might* be achievable out to 20 or 25 miles from the transmitter. But one must be careful about this as some might have difficult indoor reception at 10 miles from the transmitter while someone else might be able to achieve stable indoor reception at 30 miles from the transmitter. Some of the various parameters involved are as follows: transmitter effective radiated power (ERP), transmitter antenna height above average terrain, the type of terrain and foliage between the transmit tower and the viewer’s home, the type of receive antenna (directionality and gain), the adjustment of that antenna, the sensitivity and robustness of the DTV receiver, the type of building construction (brick, frame), the type of insulation used (foiled backed or not), the types of internal walls (simple plaster board or plaster on wire mesh), the building’s floor on which that the DTV receiver resides, and the side of the building in which the DTV receiver resides (facing towards or away from the transmitter). Therefore, nothing is better than experimenting with indoor DTV reception *before* February 17, 2009 while analog signals are still on the air to be watched and there is enough time to perform the experiment and determine some solutions.

Q: What are some troubleshooting hints that will help if DTV reception is not possible after connecting a converter box?

There are a number of things that can be tried if some of the DTV channels cannot be received reliably. These techniques should be performed *prior* to February 17, 2009 while the full-power analog stations are still on the air, and preferably performed at least a month or two before this date (if not earlier). Viewers need to be proactive rather than reactive! Remember that this is a very significant change in the broadcast system, the largest change since the addition of color in 1953 to the original black and white television system. It affects every station and every over-the-air viewer in the country, and, therefore, to have successful free, over-the-air DTV reception requires some effort by every viewer who desires to watch terrestrial broadcast television.

- 1) Check all the signal and AC power connections. Loose F-connectors on the coaxial cables that are used to connect to the antenna, splitters, amplifiers, and DTV sets/converter boxes is a common problem. Also, older components, especially those used outside and therefore exposed to the weather, can degrade significantly in their performance. Besides the obvious lack of AC power applied to the DTV set or converter box, another common problem is the

lack of AC power to indoor distribution amplifiers or the lack of DC power sent via power inserters through the RF cable to outdoor mast-mounted amplifiers. Obviously, also check for tripped circuit breakers.

- 2) If the analog television is connected to a converter box's RF output connector, make sure that the analog set is tuned to the selected RF output of the converter box (either CH 3 or CH 4). If the power-on menu or any other video is not seen when tuned to one of those two channels, then tune to the other channel. It should be noted that if there is an existing local over-the-air analog or digital station using CH 3, then select CH 4. If there is an existing local over-the-air station using CH 4, then select CH 3. If neither channel is being used off the air locally, the choice belongs to the viewer. This converter box output channel selection methodology of not using off-air channels helps to avoid any potential coaxial cable or analog television set ingress interference.
- 3) If the analog television is connected to a converter box's baseband composite video and stereo left and right audio signals, make sure that the analog TV set has the proper auxiliary baseband input selected (typically accomplished via some on-screen menu).
- 4) Initially upon connection of the box for the first time, perform a *complete* channel scan. This will clear out the channel memory and allow the viewer to determine how many channels can be received locally with the current receive system (i.e., the antenna and its adjustment, feedline cable, amplifiers, splitters, etc.). It is possible that some of these components may need to be upgraded. NOTE: channel scans should be done periodically *before* and *after* February 17, 2009 as stations may be changing their transmitter parameters, their RF channel frequency, or even their transmit antenna location. If the DTV receiver or converter box has an "Add-On" scan, then newly found channels and their related data can be included without deleting any of the previously stored channel information.
- 5) Before February 17, 2009, full-power analog stations will still be on the air, and they can be used to help troubleshoot problems with a viewer's receive equipment.
 - a. Determine the *actual* analog and digital RF channels transmitted in the region. Use www.antennaweb.org to obtain this information. Note that some stations that can be received might not appear in the listed channels from this website because they are not predicted to be in the analog signal's Grade B contour or the digital signal's noise-limited contour. Remember that some stations may only be operating at partial transmitter power before and just after the February 17, 2009 analog turn-off date, and this may affect accuracy of the predicted coverage analysis. Also note that some stations may be changing actual RF channels on or before February 17, 2009, which can also be determined from the www.antennaweb.org website.
 - b. For each desired DTV station, tune to a "nearby" analog channel that is being transmitted not only close to the actual RF channel frequency of the desired DTV channel, but also is transmitted from a nearby transmitter location. The analog signals will act as a substitute for the DTV signal to help determine propagation conditions in that general frequency band. The direction of a nearby analog television transmitter can also be found using www.antennaweb.org.
 - c. Since analog receivers act like the "window to the RF world" and allow the viewer to determine the analog signal quality directly from visual observation, determine if all

of these signals are being received at sufficient signal level (i.e., not noisy), with no severe multipath echoes (i.e., only modest “ghosting” on the screen), and with minimal impulse noise (i.e., minimal white speckles). If these conditions are met, then the receive equipment may *possibly* provide reliable DTV reception in the same frequency range. If not, then the receive system may need to be upgraded.

- 6) Contact local television stations to find out if they are all operating at full radiated power, and, if not, when they will have their facilities finalized. Some stations might be operating at reduced transmitter power levels *before* February 17, 2009, and some of them for a short time *after* February 17, 2009 may be operating at reduced power levels until they can make changes to their transmitters or their antennas. In many northern cities, changes to the antennas cannot take place until analog is turned off in the middle of winter, and making major changes to the transmit antenna (swap out old antenna for a new one or repositioning the current DTV antenna to the top of the tower for optimum coverage) cannot be made until warmer weather comes (e.g., spring).
- 7) Remember the digital “cliff effect” when adjusting an antenna, and how it will affect DTV reception. For the most part, the digital video and audio are either there or not there. Therefore, there is no “warning” (i.e., indication) from the picture and sound when adjusting an antenna that the received signal is getting better or worse. If the signal is weak enough so that it is just above this magic threshold of errors, it may vary (due to propagational fading) above and below this threshold, creating a very annoying viewing experience for the viewer. If this is the case, some additional signal margin is needed, perhaps in the form of an antenna adjustment or an antenna or feedline cable upgrade. Therefore, the DTV set’s built-in signal quality meter is useful for not only adjusting the receive antenna, but also for monitoring any dynamic signal conditions that might exist at any given time.
- 8) Outdoor antennas with coaxial cable feedlines are typically the best option, if possible, but even these components will degrade over time due to weather exposure. [Remember that the outdoor antenna prohibition was struck down in 1996 by Congress and the FCC]. If necessary, adjust the antenna for best DTV signal reception. Remember that small adjustments (slightly moving antenna location or its pointing angle) might make big differences in the received signals and their reliable reception, especially with directional high-gain antennas. If possible, move antennas away from other objects and structures, or move it to a higher location. Since the digital “cliff effect” does not allow the direct observation of signal quality on the DTV screen, use the built-in signal quality meter in the DTV set to do this (if not available from a button on the remote control, then from one of the on-screen menus). Note the optimum direction for each desired DTV station. After completing this aiming process for all the desired DTV channels, determine if there is one direction that will give acceptable DTV reception (with margin) for all the channels. This can be accomplished with another channel scan (perhaps even an “Add-On” scan or a direct RF tuning, if the converter box or DTV set has these optional features). If not, then other solutions will have to be considered (electromechanical rotor, multiple antennas, pseudo omni-directional antenna). Help in determining antenna pointing angles can be found at www.antennaweb.org.
- 9) Indoor antennas and their performance parameters are very important. Remember to select an indoor antenna that can cover all the desired DTV channels in your market. Historically, three of the most common indoor antennas from the last 50 years are rabbit ears, loops, and

bowties. For best DTV reception in some locations, it may be necessary to go with some more sophisticated indoor antennas. However, in other locations, the three simple antennas *might* work well. Nevertheless, it is critical that the viewer realize that the rabbit ears indoor antenna is best for VHF channels (CH 2- CH 13) and the loop and/or bowtie antennas are best for UHF antennas. Remember that antenna selection must be based on *actual* DTV channels and not *virtual* DTV antennas. If both VHF and UHF DTV signals are desired to be received, then two antennas are necessary. The output signals from these two antennas are typically combined in a device called a band splitter that has two input ports. One input port is for the VHF rabbit ears and passes only VHF TV channels and the other input port is for UHF loops or bowties and passes only UHF TV channels. They often have terminal screws to accept 300-Ohm twin lead cabling, with a 300-to-75-Ohm impedance converter (“balun”) inside, and they are then properly combined inside the unit for connection with one 75-Ohm coaxial cable to the DTV receiver or converter box.

- 10) Antenna feedline cable must be kept as short as possible to minimize signal loss. Also, if used with an outdoor antenna, the portion of the cable that is exposed to weather can be degraded, especially at the end where the F-connector is placed. Even coaxial cable inside the house can degrade with time, including insects or rodents eating away at the cable. Multiple shields in a coaxial cable can be helpful against local interference ingress.
- 11) The use of a distribution amplifier and passive splitter to feed more than one television set is often necessary in many installations where signals are weak and/or the antenna signal needs to be distributed to a large number of locations within the building. Using a single antenna to provide these signals is just fine as long as it provides a signal with acceptable level and quality. Sometimes the amplifier unit itself will also contain a two-way or four-way splitter internally (referred to as active splitters). However, there is always the danger that the desired incoming signal is not as weak as it seems and/or undesired incoming signals are very large compared to the desired signal. This situation leaves wide open the possibility of signal overload that can degrade DTV reception. Amplifiers should not have excessive gain as that can increase the chance of overload at their own outputs or at the DTV receiver input. Sometimes removing amplifiers or adding signal attenuators (called “pads”) to the DTV receiver input can help achieve reliable DTV reception if an overload condition is present.
- 12) Remember that indoor antenna reception is typically much more inferior for either analog or digital reception than are outdoor antenna reception. Indoor antennas provide minimal performance, and therefore should be avoided if possible. Experimentation may determine that an outdoor high-gain directional antenna is required with an *optional* preamplifier (if the desired signal is weak and no strong nearby interfering signals are present). Even if the terrain between the transmit antenna and the receive antenna is fairly flat, and both the transmit and receive antennas are fairly high above the ground, indoor antennas can become much more of a problem when the viewer is located more than 20 miles away from the transmitter. Even when the distances between the transmitter and receiver are short, there may be many situations where indoor reception is not reliable:
 - a. Interior rooms rather than exterior rooms of the building
 - b. Lower floors rather than upper floors of the building
 - c. Aluminum-sided frame houses rather than plain masonry houses

d. Foil-backed insulations versus regular insulation

13) As a last resort, place the antenna and antenna feedline cable for the best chance of reliable DTV reception.

- a. Increasing the height of the receive antenna will help.
- b. Shortening the length of the feedline cable as much as possible will help.
- c. Visiting consumer electronics stores or going on-line to various websites will provide information on available antennas and coaxial cable.

For troubleshooting help, more information can be found at:

www.fcc.gov/cgb/consumerfacts/dtvantennas.html.

MORE INFORMATION

Q: Where can more information be found regarding the DTV transition?

There are a number of different websites that can be visited:

FCC Website:	www.dtv.gov/
NTIA Website:	www.dtv2009.gov
NAB Website:	www.dtvanswers.com www.lptvanswers.com
CEA Website:	www.digitaltips.org
CEA/NAB Website:	www.antennaweb.org
Titan TV Website:	www.titantv.com
TV Fool Website:	www.tvfool.com
NCTA Website:	www.getreadyfordigitaltv.com
Independent:	www.hdtvprimer.com

GLOSSARY

- Absorption:** This term refers to a wave (i.e., signal) that is dissipated within a material and disappears. The amplitude of the wave begins to decrease at the boundary of the object, and continues to do so as the wave passes through the material until it becomes non-existent.
- Actual RF Channel:** RF stands for radio frequency. RF channel refers to the *actual* television channel being used for the digital television channel as opposed to the *virtual* channel that is used by the viewer to select DTV programs.
- Amplitude:** Amplitude is a measure of the maximum amount of movement of a wave from its equilibrium point.
- Analog TV:** Analog technology has been in use for the past 60 years (since 1941) to transmit conventional TV signals to consumers. Most current television transmissions are received through analog television sets. Analog signals vary continuously, creating fluctuations in color and brightness, but are not very efficient (by today's standards) in terms of transmission bandwidth and power. Since it directly displays on the screen any interference or impairments present at the TV set's antenna terminal, analog television receivers can be considered the "window to the RF world", and become useful as a type of test equipment for consumers and engineers alike to judge the signal propagation effects.
- Antennas:** Devices that are used to convert electromagnetic waves into signal voltages for analog and digital receivers to process. VHF antennas are much larger than UHF antennas due to the difference in wavelength at the two television frequency bands. Due to its required smaller size, UHF antennas can be designed for higher gain and directivity than VHF antennas.
- Aspect Ratio:** A numerical expression of the relationship of width to height of a TV screen. An aspect ratio of 4:3 is the numerical sequence that refers to the aspect ratio of the National Television Systems Committee (NTSC) TV screen, with a "4" unit width corresponding to a "3" unit height, proportionally, regardless of the actual size of the screen. An aspect ratio of 16:9 is the numerical sequence that refers to the aspect ratio of wide screen DTV formats for all HDTV and some SDTV (Standard Definition) and EDTV (Enhanced Definition) video. A "16" unit width corresponds to a "9" unit height proportionally, regardless of the actual size of the screen. The widescreen 16:9 numerical sequence provides a viewing experience very similar to that of 35 mm movies.
- ATSC:** An acronym for Advanced Television Systems Committee, and is the name of the DTV system used by broadcasters in the U.S.
- Barn Doors:** Also referred to as "pillar box." See definition for pillar box.
- Bow-Tie Antenna:** A bow tie antenna, also called a UHF fan dipole antenna, comes in the shape of a bow tie, and is used for UHF reception. It uses triangular

elements instead of rods, which give it a greatly increased bandwidth (e.g., the entire UHF band from CH 14 to CH 69). Sometimes a mesh back reflector is used to improve its directionality. It is useful for UHF DTV television reception (not VHF).

- Broadcast Spectrum:** Range of electromagnetic radio frequencies used in the transmission of television signals. Broadcast spectrum is defined in terms of three bands: Low-VHF (CH 2 – CH 6), High-VHF (CH 7 – CH 13), and UHF (CH 14 – CH 69 before 2/17/09 and CH 14 – CH 51 after 2/17/09).
- Broadcasting:** The act of transmitting television signals using electromagnetic waves from a TV station's transmit antenna to a viewer's receive antenna for the purpose of conveying information in the form of video and audio. This is also called free, over-the-air terrestrial broadcast television.
- Coaxial Cable:** Round cable with a center conductor and an outer shield separated by a dielectric material and encapsulated in a plastic-like material. For consumer use, this cable is typically 75-Ohms.
- Closed Captioning:** A service that allows a viewer with hearing disabilities to read dialogue on the television screen. The FCC requires basic closed captioning in all analog television sets 13" and larger that were manufactured after July 1993. The FCC requires both basic and advanced closed captioning in all DTV sets. DTV converter boxes are only required to pass basic closed captioning through to the legacy analog television set, but are allowed to decode within the converter box advanced closed captioning for display on the analog television set.
- Codec:** This term is short for "Coder-Decoder." A codec is a device that converts studio analog video and audio "baseband" signals into a digital format while removing significant amounts of redundancy (i.e., performs compression), thus preparing the signals for transmission at the DTV transmitter site. It also adds back in most of the redundancy (i.e., performs decompression) and converts the received digital signals back into an analog format in the DTV receiver.
- Composite Video:** This is the most common way to connect peripherals and other components, using a pair of wires with a yellow RCA jack connector. The video contains a combination of luminance (brightness) and chrominance (color) together on one cable. Often, stereo audio is transmitted on two separate pairs of wires (left and right) with a white and red RCA jack connector.
- Compression:** Compression refers to the reduction of the size of digital data files by removing redundant and/or non-critical information ("data" being the elements of video, audio and other "information"). Digital TV in the U.S. would not be possible without compression.
- Computer Input:** Some HDTV sets have an input like SVGA or VGA that allows the TV sets to be connected to computers.

- D/A Converter Box:** A stand-alone electronic device that receives and converts off-air ATSC digital signals (of all video formats) into an analog NTSC format for display on a legacy analog television receiver. This permits legacy analog television sets to still be used with over-the-air digital broadcast signals after analog television signals are turned-off.
- Datacasting:** Datacasting is the act of providing enhanced options offered with some digital programming to provide additional program material or non-program related resources. This allows viewers the ability to download data (video, audio, text, graphics, maps, services, etc.) to specially-equipped computers, cache boxes, set-top boxes, or DTV receivers.
- Decoder:** See "codec." A device or program that translates encoded data into its original format (i.e., it decodes or decompresses the data).
- Department of Commerce:** Department whose responsibility is to “foster, serve, and promote the Nation’s economic development and technological advancement.”
- Diffraction:** This term refers to a wave (i.e., signal) that bends around an object or through openings in an object. Both the shape and the direction of a wave changes when it is diffracted at some boundary, such as what happens when a TV signal passes around a building to partially fill-in behind the building where an electronic “shadow” exists or when a TV signal passes through a window of an aluminum-sided house.
- Digital:** Digital refers to the computer-like circuitry in which data-carrying signals are restricted to one of two voltage levels, corresponding to logic 1 or 0. It is a more efficient method of storing, processing, and transmitting information through the use of computer code.
- Digital Cable:** A service provided by many cable providers, digital cable offers viewers more channels. Contrary to many consumers' beliefs, digital cable is *not* the same as High- Definition Television (HDTV) or digital television (DTV); rather digital cable simply offers cable subscribers the options of paying for more services.
- Digital Monitor:** DTV monitors are televisions that can display a digital signal but lack an integrated tuner (unlike an integrated digital set), and thus cannot receive an over-the-air digital broadcast signal from an antenna without the use of an additional set-top box.
- Digital Tuner:** A digital tuner serves as the decoder required to receive and display digital broadcast television. It can be included inside a TV set, a set-top box, a converter box, a VCR, or a DVR. It is also called an ATSC tuner.
- Digital Television:** Digital Television (DTV) is the umbrella term used for the new broadcasting system that uses compute-like code to transmit pictures and sound. It encompasses all types of digital broadcasting, including High-definition Television (HDTV), Enhanced Definition Television (EDTV), Standard Definition Television (SDTV), datacasting, multicasting, handheld/mobile, and interactivity.

- Dolby Digital Sound:** Form of multi-channel digital sound that provides efficient encoding and noise reduction for high quality surround sound with 5.1 channels (5 full bandwidth CD-quality channels plus 1 low-frequency sub-woofer channel).
- Downconvert:** A process by which a high resolution signal is reduced to a lower resolution for display. In converter boxes, any of the higher resolution digital formats (EDTV or HDTV) are converted to lower resolutions for display on a legacy analog television receiver.
- Dolby Surround Sound:** This is a digital surround sound technology used in movie theaters and upscale home theater systems that enhances audio. Home theater components with this technology work in conjunction with a "5.1-speaker" system (five full bandwidth speakers plus a low-frequency subwoofer) to produce true-to-life audio that draws the listener into the onscreen action.
- DTV Transition:** The process initiated by the FCC in 1987 to convert the entire terrestrial television broadcast industry from analog to digital, starting with the mandated DTV turn-on in 1999, culminating with the Congressional requirement to cease *full-power* analog broadcasting on February 17, 2009.
- Enhanced Definition TV:** There are *three* main digital formats – HDTV, EDTV, and SDTV. Enhanced Definition (EDTV) provides a middle-ground resolution and picture quality of all digital broadcast formats. Despite having only 480 active lines like the traditional analog television system, the increased resolution comes from *progressive* scanning of the picture, reducing interlaced artifacts that typically occur with motion in the video. It also has both the traditional 4:3 aspect ratio and the new 16:9 wide aspect ratio formats. (**Note:** EDTV and digital TV are *not* the same thing -- EDTV is just *one* format of digital TV.)
- EPG:** Electronic Program Guide (EPG) that is part of the extra data (besides video and audio) transmitted in the DTV data stream that is a list of upcoming TV programming for a given digital channel or sub-channel.
- Frequency:** Frequency is a measure of how often a wave repetitively changes, and is measured in cycles per second or Hertz.
- High Definition TV:** There are *three* main digital formats – HDTV, EDTV, and SDTV. High Definition (HDTV) provides the highest resolution and picture quality of all digital broadcast formats. It has two primary resolutions: 720p (720 active lines, with progressive scanning) and 1080i (1080 active lines, with interlaced scanning). Combined with digitally enhanced sound technology, HDTV sets new standards for sound and picture quality in television. (**Note:** HDTV and digital TV are *not* the same thing -- HDTV is just *one* format of digital TV.)
- Household:** All of the people who occupy a housing unit. A housing unit is a house, an apartment, a mobile home, a group of rooms, or a single room occupied as separate living quarters. Separate living quarters are those in which the

occupants live separately from any other people in the building and that have direct access from the outside of the building or through a common hall. This definition is important in the NTIA's Coupon Eligible Converter Box (CECB) program where up to two \$40 coupons are available to an eligible household.

- Interference:** Unwanted electrical signals or noise causing impairments in the digital video or audio. Interference can come from other television signals (analog or digital) or they can come from devices such as vacuum cleaners and microwave ovens.
- Interlaced Scanning:** This process divides and presents each video frame as two sequential fields. Imagine a video frame being divided by the odd and even horizontal lines that make up the picture. The first field presents the odd lines; the second field represents the even lines. The fields are aligned and timed so that, with a still image, the human eye blends the two fields together and sees them as one. Motion in the image makes the fields slightly noticeable. Interlace scanning allows only half the lines to be transmitted and presented at any given moment, and is a simple form of video compression.
- Letterbox:** Letterbox refers to the image of a wide-screen picture on a standard 4:3 aspect ratio television screen, typically with black bars above and below. It is used to maintain the original aspect ratio of the original source (usually a theatrical motion picture of 16:9 aspect ratio or wider).
- Loop Antenna:** A loop antenna has a continuous conducting path leading from one conductor of a two-wire transmission line to the other conductor. It is useful for UHF DTV television reception (not VHF).
- Multicasting:** The ability to transmit multiple standard definition programs at the same time using a single digital RF broadcast channel. The option to multicast was made possible by very efficient digital compression technology to allow each digital broadcast station to split its bit stream into 2, 3, 4 or more individual channels of programming and/or data services in one 6 MHz RF channel. (For example, on channel 7, you could watch 7-1, 7-2, 7-3 or 7-4.)
- Must Carry:** This refers to the legal obligation of cable companies to carry analog or digital signals of over-the-air local broadcasters on their cable systems (if there is no contractual retransmission agreement between the broadcast station and the cable company).
- NTIA:** The National Telecommunication Information Administration (NTIA), a group within the Department of Commerce, is the President's principal adviser on telecommunications and information policy issues.
- NTSC:** NTSC is the acronym that stands for National Television Systems Committee" and the name of the current analog transmission standard used in the U.S. The first "version" of this committee created the black

and white television standard in May 1941, and the second “version” of this committee created the color television standard in December 1953.

- NTSC Tuner:** A device that tunes and decodes the traditional analog television signals, providing standard definition video and stereo audio outputs.
- Over-the-Air:** Over-the-air (OTA) refers to the transmission and reception of information in a wireless communication system. This is also referred to as terrestrial broadcasting.
- Pillar Box:** A term that is used in television production to describe the effect that occurs when a 4:3 image is viewed on a 16:9 screen. When this happens, viewers see black bars on the sides of the screen or a “pillar box”. This is also referred to as "barn doors." See “barn doors.”
- Pixel:** Pixel is actually two words jammed together: Picture and Element. A pixel is the tiniest sample of video information that is capable of being sampled and transmitted through a system. They are the "little squares" that make up an overall picture, just as tiny pieces of stone make up a mosaic picture when viewed from a minimum distance.
- Postage Stamp:** Occurs when an image is both letter-boxed and pillar-boxed, creating a smaller box within your screen.
- Progressive Scanning:** This process presents each video frame as one field whose video lines are presented consecutively, i.e., in order (progressively). At the same number of scan lines, a progressively scanned picture produces a higher quality picture than interlaced scan.
- Rabbit-Ears Antenna:** A pair of antenna elements connected as a dipole antenna to create an indoor antenna that can be easily adjusted by a viewer. Rabbit ears are useful for DTV VHF television reception (not UHF).
- Reflection:** This term refers to a wave (i.e., signal) that bounces off an object or surface, and changes the direction of the wave. The amount of signal that gets reflected depends on many variables, including but not limited to the material of the object, the frequency of the wave, and the smoothness of the object. Specular reflection causes a single wave to bounce off the object due to a smooth surface while diffuse reflection causes the wave to reflect in many directions due to a rough surface. The reflected wave has the same frequency and wavelength as the incident signal, such as what happens when a TV signal reflects off a water tower or smooth building and changes the direction of the signal.
- Refraction:** This term refers to a wave (i.e., signal) that bends as it passes into and through an object. The amount of bending that occurs at a boundary of two different materials depends on the difference in wave speed in each of the two materials. The refracted wave has the same frequency and wavelength as the incident signal, such as when happens when a TV signal refracts off the atmospheric layers above the earth and bends the signal slightly to cause it to reach areas slightly beyond the optical horizon.

- Resolution:** Amount of detail that can be seen in a broadcast visual image, typically defined in number of active horizontal lines (480, 720, and 1080) in one video frame and type of scanning (interlace “i” or progressive “p”). The ATSC standard includes several different video resolution formats: 480i, 480p, 720p, 1080i.
- RF:** RF stands for Radio Frequency, which for television channels lies between 54 MHz and 803 MHz (before February 17, 2009), and between 54 MHz and 698 MHz (after February 17, 2009).
- Standard Definition TV:** There are *three* main digital formats – HDTV, EDTV, and SDTV. SDTV, even though it contains 480 active lines interlaced into one frame like the analog television system, typically *does* produce better quality images than that of traditional analog TV and pictures somewhat akin to digital cable because it is not degraded by the NTSC analog *transmission* limitations. However, its images are not nearly as sharp as the images from the ultimate form of digital television: High-definition TV (HDTV).
- Set-top Converter Box:** This small electronic unit sits on top of the viewer's analog TV, receives a Digital TV signal from an outdoor or indoor antenna, converts it to an analog NTSC signal, and then sends that signal to the legacy analog TV for viewing.
- Spectrum:** Range of electromagnetic radio frequencies used in the transmission of radio, data, and video.
- Speed:** The speed of a traveling wave is the amount of distance traveled in a given amount of time, such as miles per hour or meters per second. Electromagnetic waves, such as those used to transmit analog or digital signals over the air, travel at 186,000 miles/second (300,000 km/second). This means that TV signals travel about 1 mile in 5.4 μsecs (5.4×10^{-6} seconds).
- Terrestrial Broadcasting:** This is a broadcast signal transmitted "over-the-air" from a TV station's transmit antenna to an antenna on a viewer's building. This is also referred to as "over-the-air" (OTA) broadcasting.
- Upconverting:** Process by which a standard definition picture is changed to a *simulated* high-definition picture by interpolating some of the "missing" high-definition data. While not absolutely true HDTV (even though the video resolution is the same), it can look good to a consumer if done well.
- Virtual DTV Channel:** This is the number used by the viewer to select various DTV programs. It is made up of two parts. The first part is the major channel number that references to the original analog channel (e.g., CH 5). The second part is the minor channel number or the sub-channel number that references any digital programs (e.g., 5-1, 5-2, 5-3, etc.). The major and minor channel numbers are determined when the DTV receiver or converter scans the entire television band looking for detectable DTV signals, and stores the appropriate channel reference information upon finding existing channels. The redirection of the DTV set's tuner from the entered *virtual* channel to

the *actual* tuned RF channel is similar to call forwarding in the telephone world.

Yagi Antenna:

Yagi antenna is named after Hidetsugu Yagi, a Japanese physicist. It is a highly directional, high-gain antenna that achieves its directivity with added elements called directors (at the front of the antenna) and reflectors (at the rear of the antenna). However, it typically does not have a large bandwidth, which is inversely proportional to its gain. It is typically used for UHF frequencies.

Wavelength:

A term that describes the separation distance between identical points on a traveling wave, such as between the maximums (crest) or between the minimums (trough). This distance is often represented by the Greek character lambda (λ).

Waves:

A wave is an oscillation that travels (i.e., propagates) from one place to another, carrying energy with it. Examples where waves exist are a guitar string after being plucked, the human ear drum responding to sound, water that has been disturbed by a falling object, and information such as analog or digital television signals transmitted wirelessly through the air. Waves have the following properties: amplitude, frequency, speed, and wavelength. Two types of waves are: plane waves and circular waves, each dependent on how they were created. As a wave encounters an object or a surface, four things can happen at this boundary between two materials: reflection, refraction, diffraction, and absorption.

Wide Screen:

A term given to picture displays with a wider aspect ratio than NTSC's 4:3. In the ATSC standard, digital HDTV or SDTV is referred to as "16:9 wide screen." Most motion pictures also have at least a 16:9 wide screen aspect ratio. Most Digital TVs have a screen that is wider than it is tall (if a Digital TV screen is nine inches high, it's 16 inches wide.) When watching a show recorded in the wide screen format on a Digital TV, viewers see more of the movie, while when viewing wide screen format on an analog TV, cropped edges are evident unless the entire picture is squeezed down (letter box) with black bars on the top and bottom of the picture.

Parting Shots

By Larry Bloomfield

According to FCC DOC-285458A1.doc, there are a total of 8620 television transmitters in the United States. By law, on February 17, 2008, all **FULL POWER ANALOG** Television stations must switch over to a digitally transmitted signal and cease to operate in analog. According to FCC DOC-285458A1.doc, as of JUNE 30, 2008, there are 1758 full power television stations and that is broken down as follows:

UHF COMMERCIAL TV 796
VHF COMMERCIAL TV 582
UHF EDUCATIONAL TV 252
VHF EDUCATIONAL TV 128
TOTAL Full Power 1758

This is only slightly over 20%.

According to this same document, there are 6862 television transmitters that are **NOT REQUIRED** to make this transition. This is broken down as follows:

ALL CLASS A STATIONS (3KW) 550
ALL TRANSLATORS 4040
ALL LOW POWER TV (1KW or less) 2272
The total for these three categories is 6862

If you have a newer television set that can receive both digital and analog signals, you should have no problem. If, however you have an older (legacy) television set that does not have a digital tuner and you live in an area served by one or more **FULL POWER** stations that will be making the transition in February, you will need a converter box to receive those stations that will switch over to digital. There are coupons available to help off-set the cost of a converter box.

Should you live in an area like where I live, Florence, OR, that is not served by any full power television station and is only served by translators, or you live in an area like Bend, OR that is served by both types of signals, (i.e.: KTVZ – NBC – full power or KFXO – FOX Low Power) you may have a problem as **not all converter boxes are created equal**. Unless the converter box that you get has a feature called “PASS THROUGH,” once installed you will no longer be able to receive any of those analog stations that will not be making the transition to digital. Should you get a converter box that does not have the pass through feature, try to return it for one that does have it. If you cannot exchange it, you may wish to connect your antenna, converter box and legacy television set according to the diagram to the right. With the switch in the A position (A for Antenna), your set is connected directly to the antenna permitting you to receive analog signals. In the B position (B for Box), your set is connected through the converter box permitting you to receive digital signals

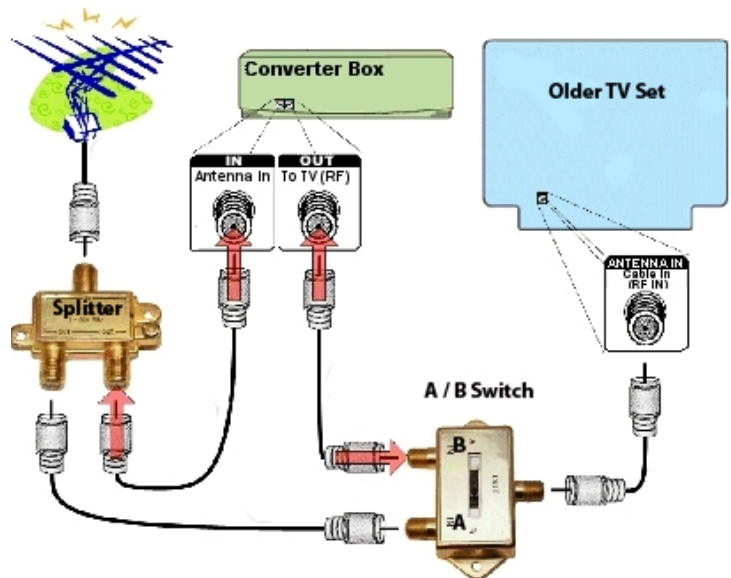

The only people you can blame for this boondoggle are the FCC. The transition should have been for everyone, not just part of the TV industry. It will be interesting to see what February 18th will be like.

So

What do you think?



The opinions expressed herein are those of the individual authors and do not necessarily reflect the opinions or positions of their friends, employers, associates or publishers of the Tech-Notes. Material in this edition may be used with proper attribution and notification.

Note: Some of the material in this edition was gleaned from one or more of the following internet mailing lists: broadcast@radiolists.net, radio-tech@broadcast.net, opendtv@freelists.org, TV-tech@broadcast.net.



How to subscribe

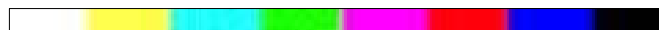

Tech-Notes are available two ways:

1. *Tech-Notes are available on our website in PDF (Portable Document File) format with pictures, drawings etc. These can be rather large files and are not recommended if you have dial-up service or travel. [Click Here](#) or go to technotes-on@tech-notes.tv to subscribe. You will be notified when each edition is posted. (We no longer just send the Tech-Notes out as an attachment.)*

To unsubscribe, Please visit our website and follow the directions: [Click Here](#) or <http://www.tech-notes.tv/Subscription/un-subscription.htm>

Please visit our web page to review our policies and to see any addition information. <http://www.Tech-Notes.tv>

Thanks.



Return to Index